

KIWI SLIDING HOOK FLYER - Single Drive -

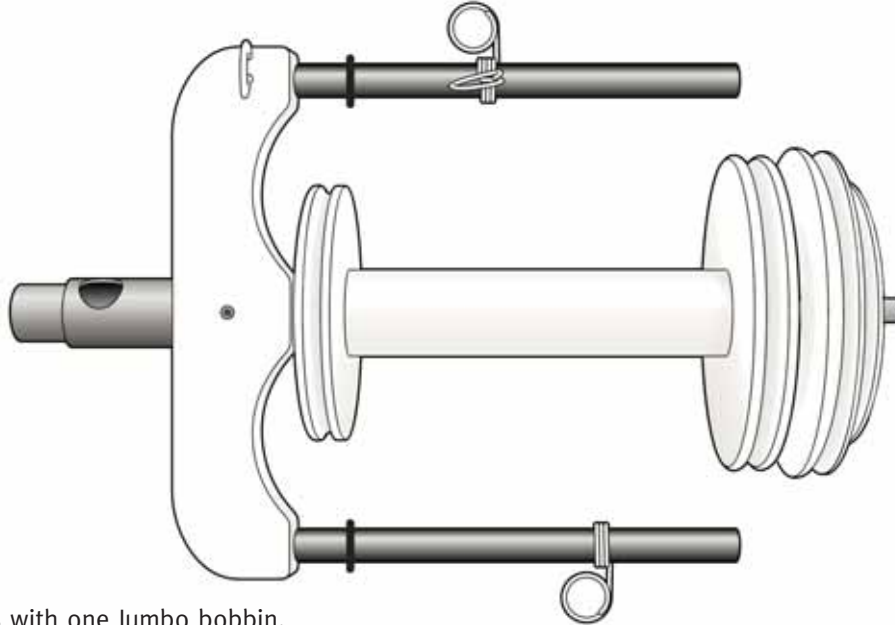

- Flyer comes with one Jumbo bobbin.
- Fill your bobbins evenly with the squeeze and slide stainless steel yarn guides.
- Graphite - fibreglass arms result in a light and strong flyer.
- The 2 speed pulley allows a wide range of yarns to be spun.

Wood finish

We recommend the wood be sealed with a wax or oil finish before use to protect and enhance it's natural beauty. Ashford wax polish is ideal for this purpose.

1. Use the allen key supplied to remove the screw securing the front flyer bearing from underneath the top rail.
 2. Substitute the jumbo front flyer bearing and secure it in position with the same screw keeping the Ashford logo facing out.
 3. Thread the 2 hooks into the pilot holes in the flyer base.
 4. Slide the rubber O-rings onto the flyer arms until opposite the bobbin end.
 5. Squeeze and slide the stainless steel yarn guides onto the flyer arms.
 6. Place a jumbo bobbin onto the flyer shaft. Then push the flyer whorl onto the end of the shaft.
 7. Locate the pin on the end of the flyer whorl into the back bearing and "click" the orifice end of the flyer into the front bearing. A drop of oil occasionally on the flyer and bobbin bearings will make treadling easier and reduce noise.
 8. Position the brake band over the bobbin and hook the spring to the cup hook. If the existing brake band is too short replace it with the new band and tension springs supplied. Turn the tension knob until the tension springs just starts to stretch. When spinning the springs should not stretch more than their own length.
 9. When first using your Kiwi Jumbo Sliding Hook Flyer for soft textured yarns, position the new longer drive belt in the large flyer and small wheel grooves. This gives a flyer to wheel ratio of 4:1. For finer yarns position the drive belt in the small flyer and large wheel grooves. This gives a ratio of 5:1.
 10. Attach the threading hook to your spinning wheel with the cotton tape.
 11. Tie a leader yarn approx. 1.5m / 5' to the bobbin centre and feed it through the yarn guide, around the flyer hook and through the orifice.
 12. As your bobbin fills, squeeze and slide the yarn guide to fill your bobbin evenly.
 13. When spinning fine yarns, push the nylon jumbo orifice bush into the flyer orifice.
 14. To convert your wheel back to using the standard flyer, click the nylon jumbo bearing reducer bush into the front flyer bearing.
- When not using your Kiwi release the tension on the drive belt by taking it off the flyer whorl.

Happy Spinning!