

ASHFORD COUNTRY SPINNER

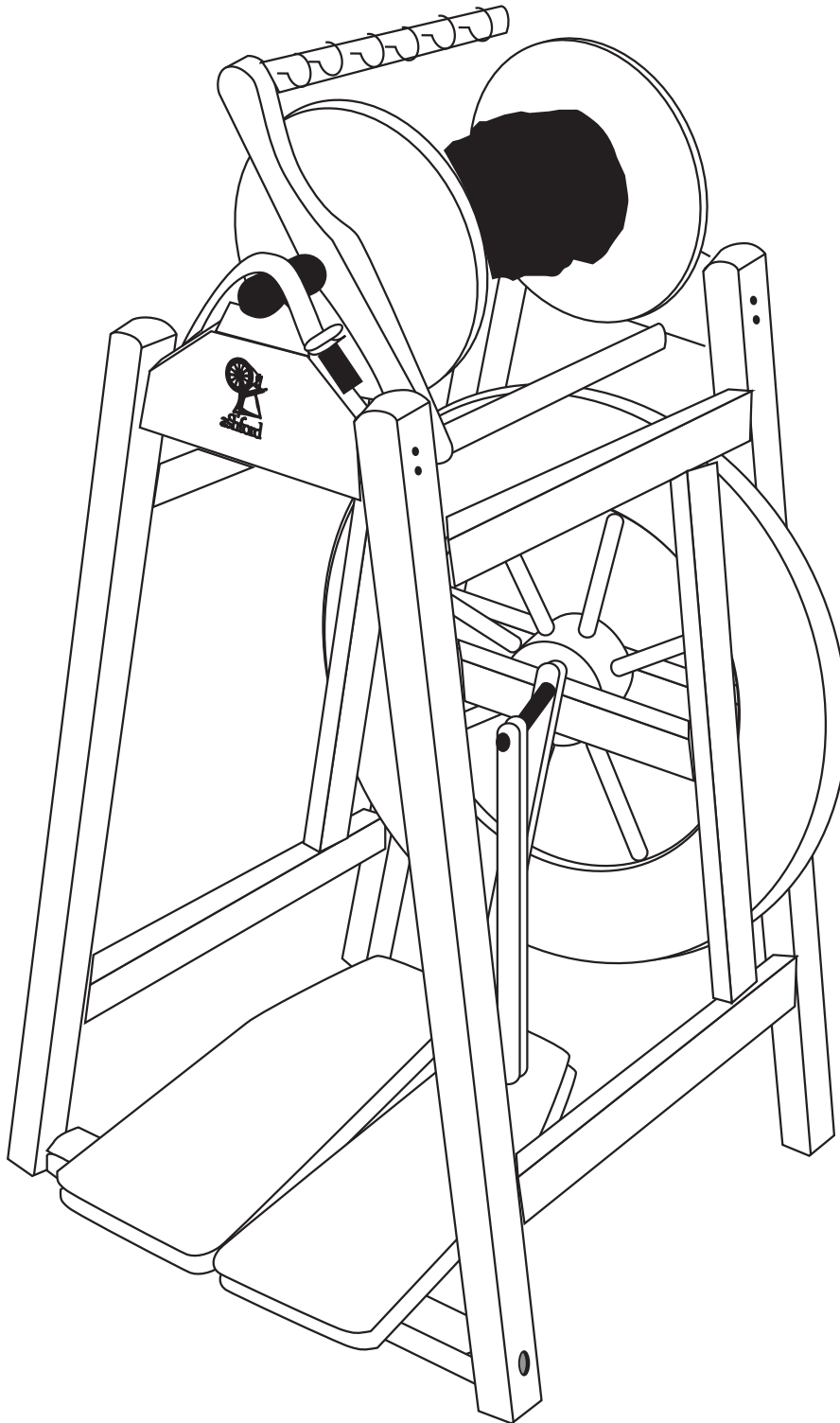

Tools Required:
Screwdriver, Hammer, Candle Wax, Oil

Before Commencing:
Read assembly instructions completely, identify the parts and note the assembly sequence. Candle wax rubbed on all screws will make assembly easier.

Finishing the Wood:
We recommend that the wood surfaces be waxed before assembly. This protects the kiln dried wood from climatic changes and enhances the beauty of the wood.

For the Ultimate Finish:
Use the special, natural, new formula Ashford Wax Finish.
The Silver Beech Tree is a native of New Zealand and has a lovely variety of colour and grain.
The Ashford Wax Finish will enhance the natural colours and beauty of the wood.

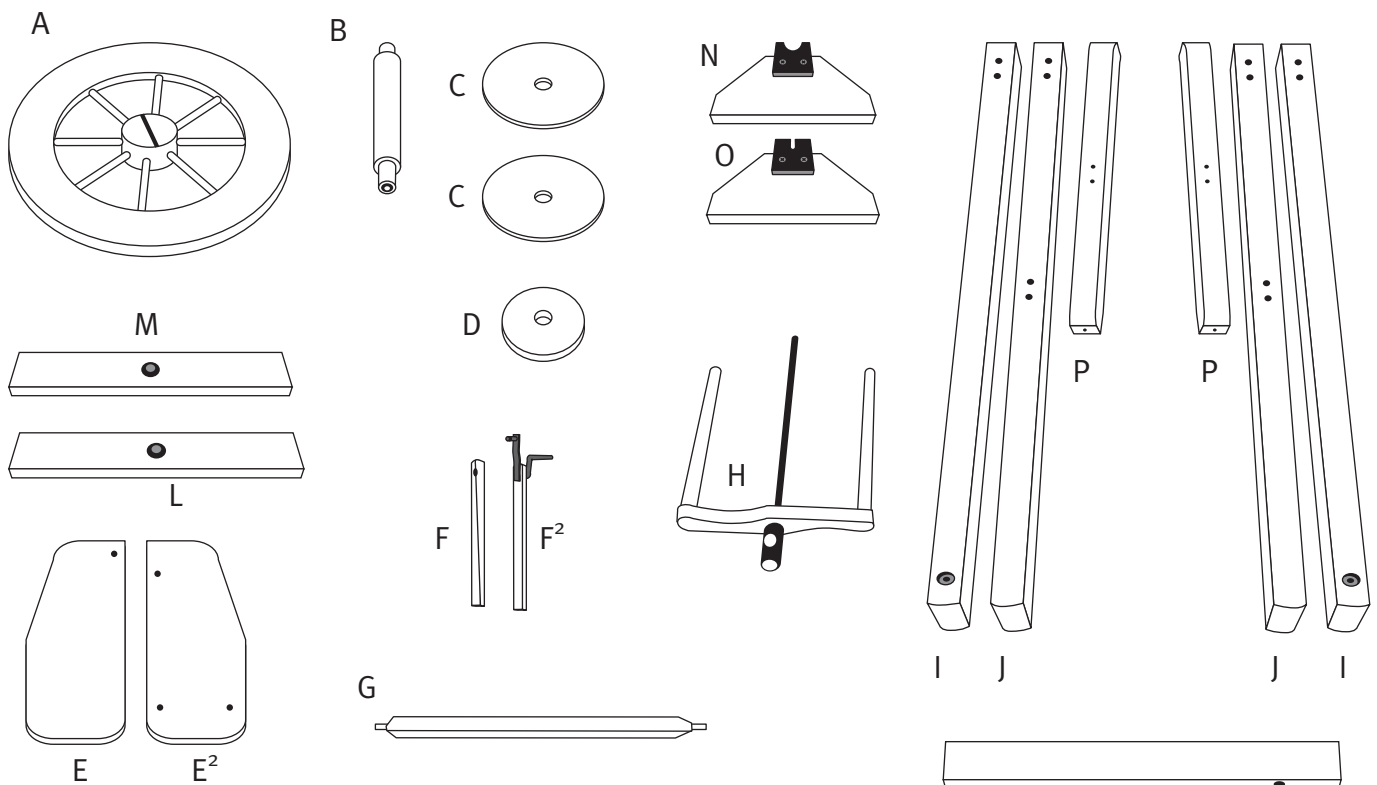

PARTS LIST

A	Wheel	H	Flyer
B	Bobbin Centre	I	Front Legs (pair)
C	Bobbin Ends	J	Back Legs (pair)
D	Bobbin Whorl	K	Side Rails
E	Left Treadle Board	L	Front Wheel Supports
E ²	Right Treadle Board	M	Back Wheel Support
F	Con Rod	N	Front Flyer Support
F ²	Crank Con Rod	O	Back Flyer Support
G	Treadle Rail	P	Side Support Rails

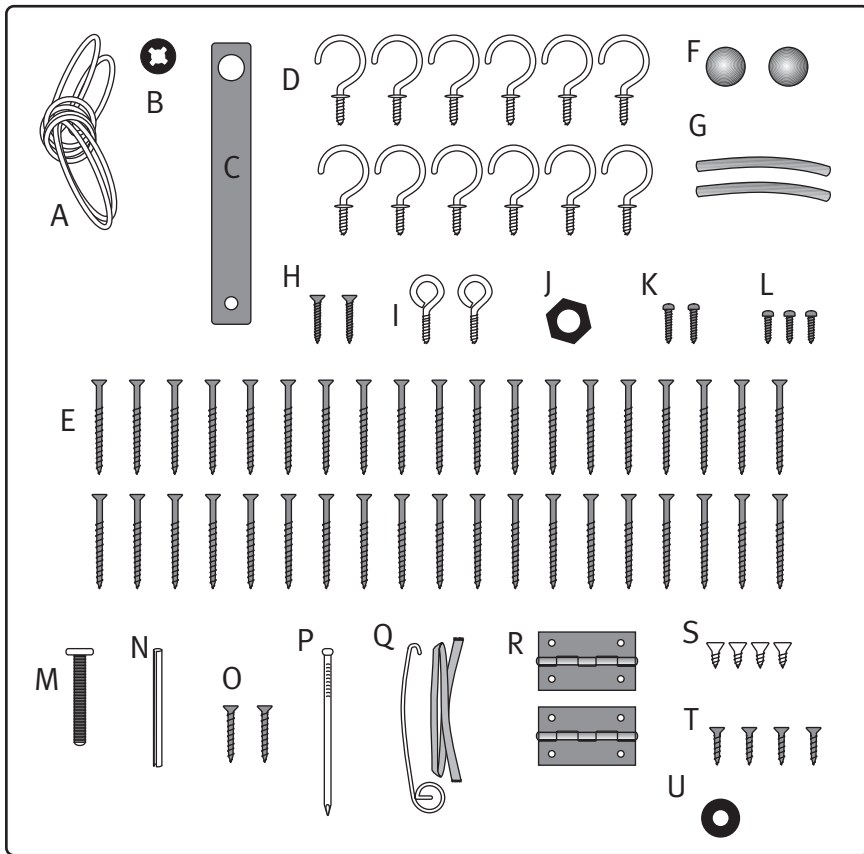

- A Drive Belt
- B E Clip
- C Leather Brake
- D Flyer Hooks
- E 50mm (2") Screws
- F Dome Caps
- G Flexible Joint
- H 25mm (1") Screws
- I Screw Eyes
- J Hex Nut
- K 19mm (3/4") Pan Head Screws
- L 16mm (5/8") Pan Head Screws
- M 50mm (2") Bolt
- N Hub Pin
- O 30mm (1 1/4") Screws
- P Nail
- Q Threader Hook & Tape
- R Hinges
- S 13mm (1/2") Screws
- T 19mm (3/4") Screws
- U Nylon Washer

Step 1
Screw the Flyer hooks into the flyer arms.

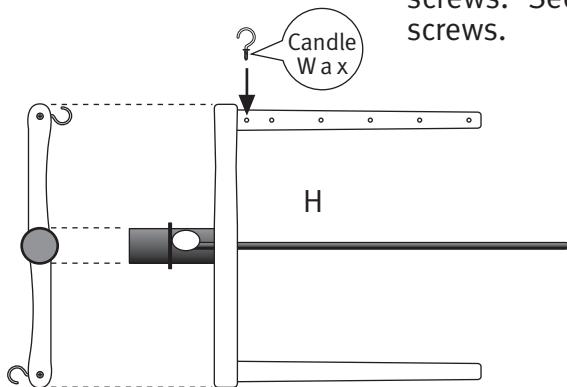

Step 2
Assemble the bobbin by placing one bobbin end and the bobbin whorl over the long end of bobbin centre. Secure with 50mm (2") screws. Secure other bobbin end to the centre with 25mm (1") screws.

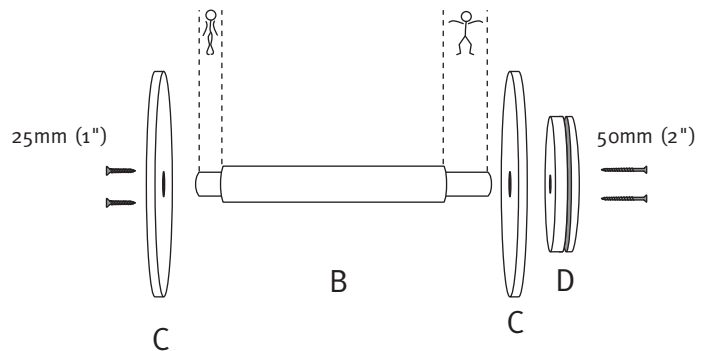

Step 3
Use 50mm (2") screw to assemble rails **K** to the front legs **I**. Then secure support rails **P** between rails **K** with 50mm (2") screws.

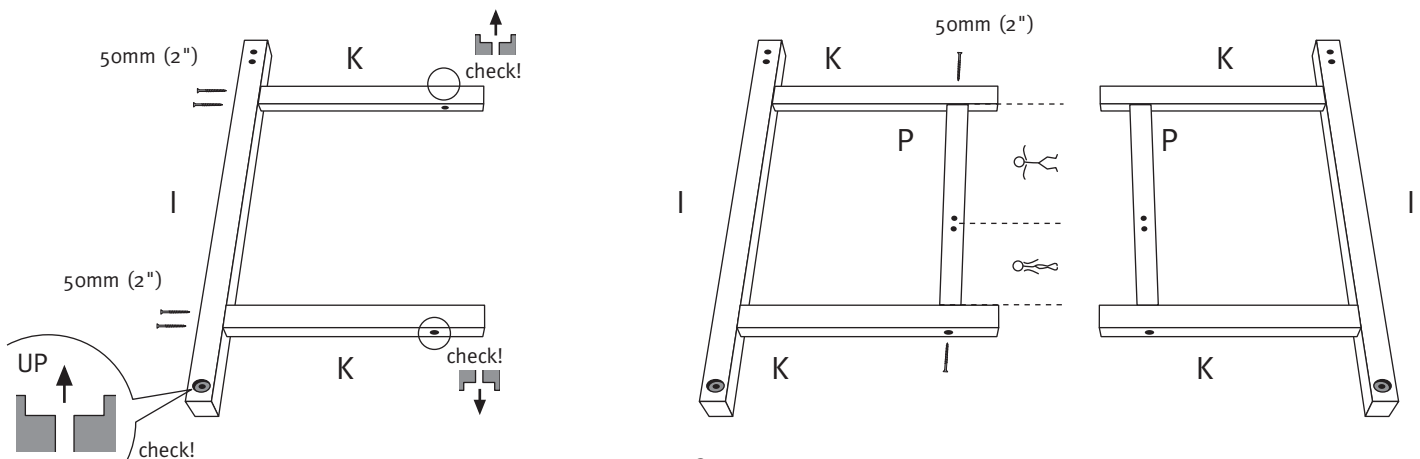

Step 4

With the bearing facing inwards locate the front flyer support **N** between legs **I** and secure with 50mm (2") screws. Partially tighten.

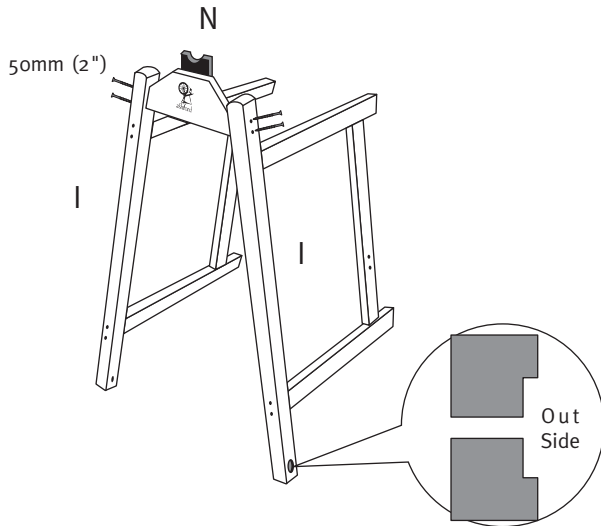

Step 5

Secure 2 Hinges to treadle rail **G** with 19mm (3/4") Screws, and use 13mm (1/2") Screws to secure left treadle board **E** to Hinges. Then secure right treadle board **E²** to treadle rail **G** with 30mm (1 1/4") Screws.

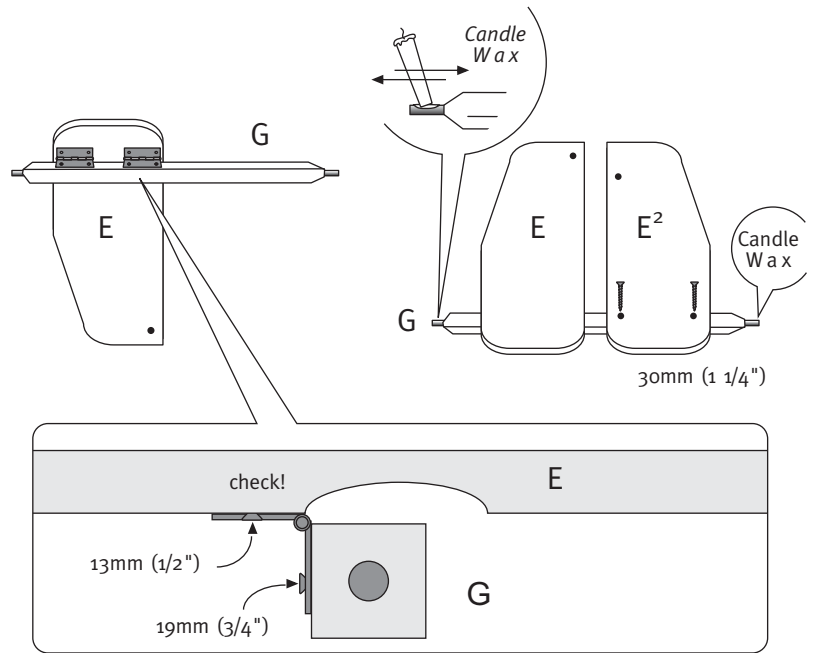

Step 6

Place treadle assembly between legs **I** and tighten the screws into **N**.

Step 7

With 50mm (2") screws, secure the front wheel support **L** between support rails **P**. Keep the ball bearing facing rear.

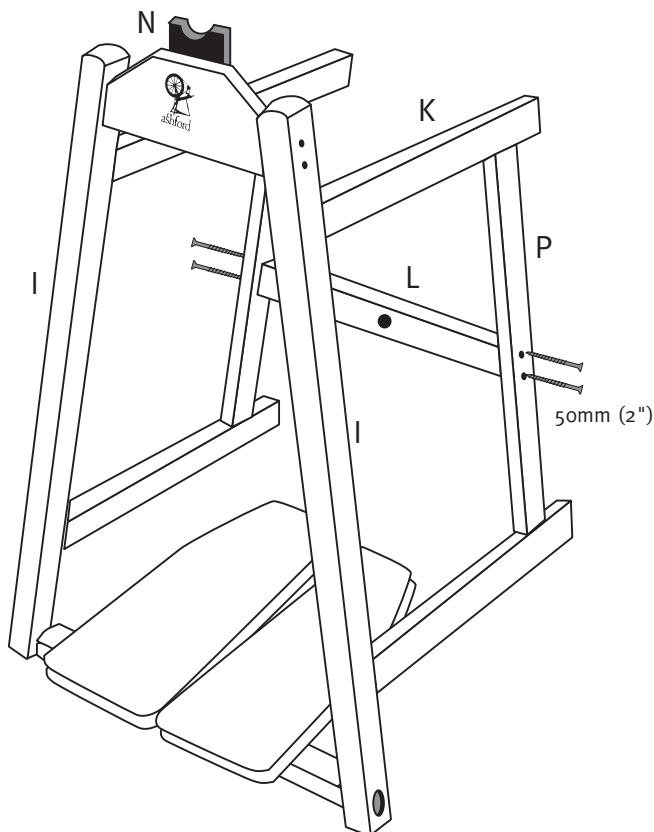

Step 8

Secure one flexible joint into the bottom of each con rod **F** and **F²** with 16mm (5/8") pan head screw. Put the nylon washer onto the crank, and then place the con rod **F** on the crank with the bearing facing out, and secure with the O clip.

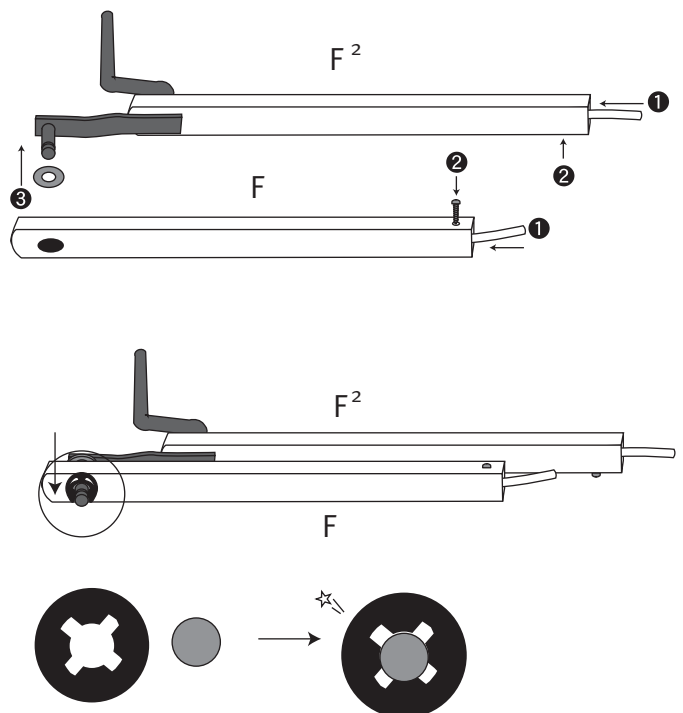

Step 9

Push the crank through the front of the wheel support **L**. Then place the wheel on the crank with the tension pin slot to the rear.

Note: Place the drive belt around the wheel.

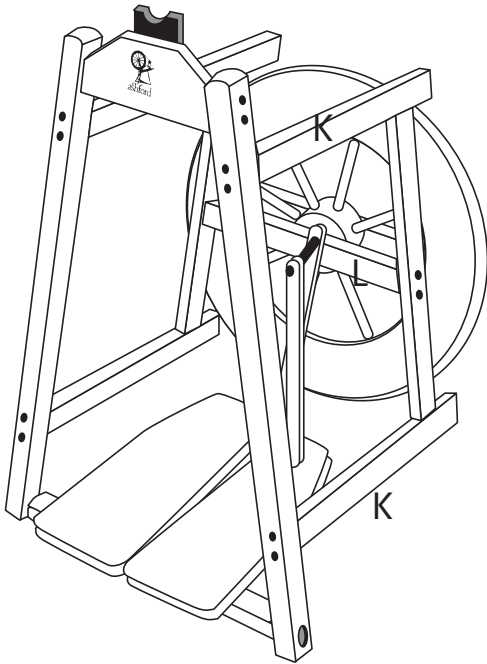

Step 10

Make sure the drive belt is outside the top side rails **K**. Then secure the back legs **J** to the top and bottom rails **K** using 50mm (2") screws.

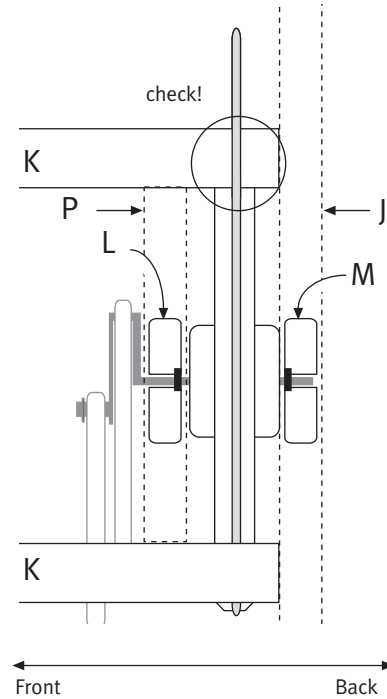

Step 11

With the ball bearing facing the wheel place the wheel support **M** on the crank and secure between legs **J**, with 50mm (2") screws. With the bearing facing inwards locate the rear flyer support **O** between legs **J** and secure with 50mm (2") screws.

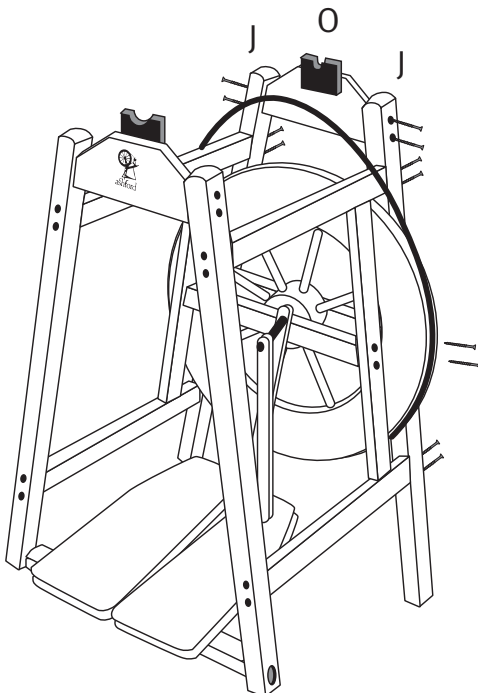

Step 12

Line up the hole in the crank and slot in the hub with the nail provided. Remove the nail and carefully tap in the tension pin.

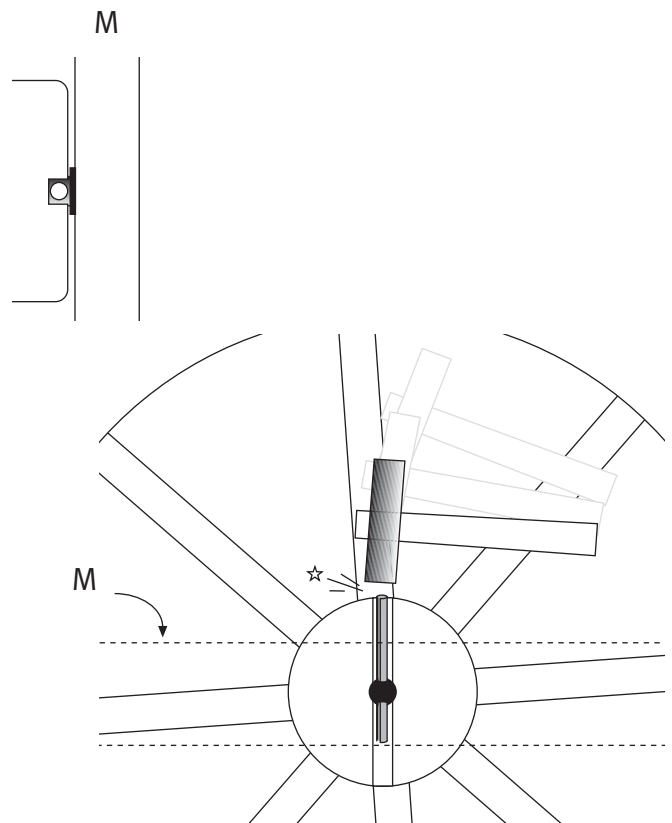

Step 13

Attach each flexible joint to the treadle boards using a 19mm (3/4") pan head screw. Leave approximate 16mm (5/8") gap between the con rod and treadle board.

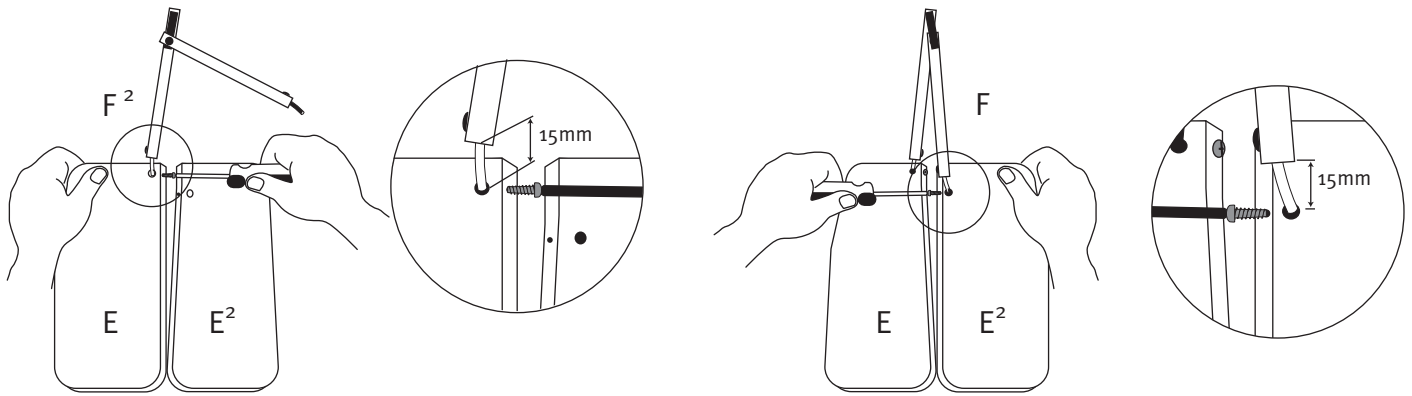

Step 14

Place the bobbin on the flyer shaft and insert it between the bearings, placing drive band on the pulley at the same time.

Step 15

Push the dome caps onto the steel treadle pins protruding through legs I.

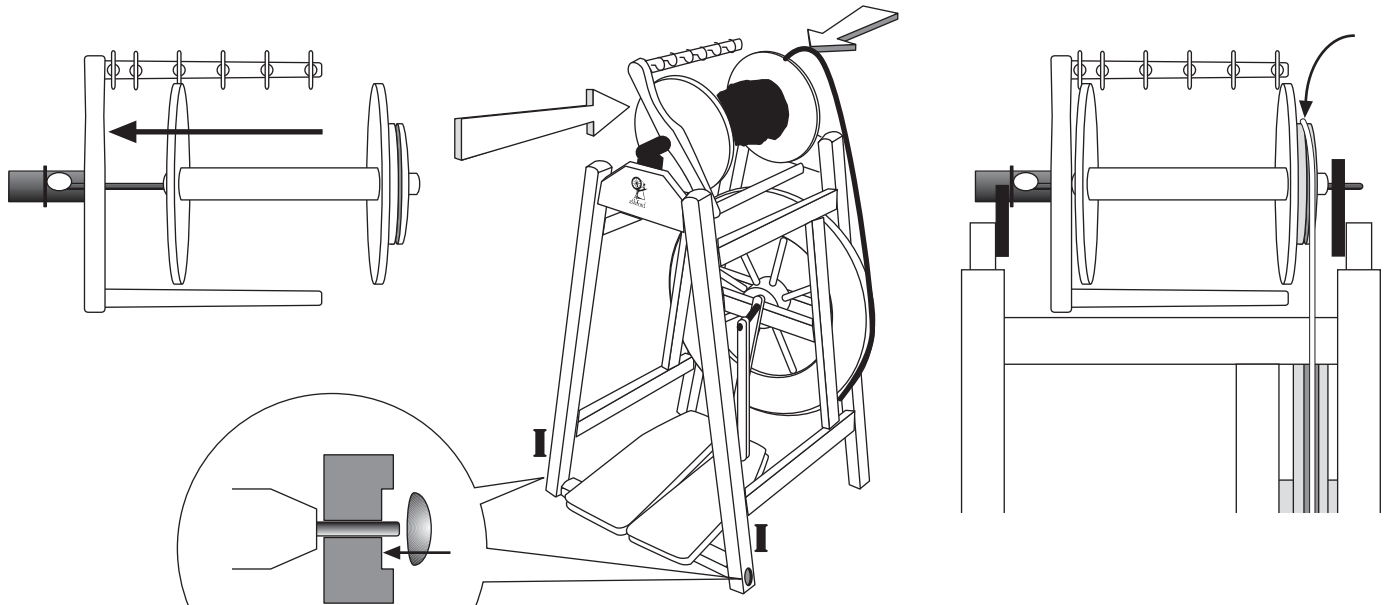

Step 16

Screw the leather brake to the left side of the front flyer support with a 16mm (5/8") pan head screw.

Step 17

Screw the two screw eyes into the pilot holes in the right hand side of the front flyer support.

Step 18

Push the 50mm (2") bolt through the leather brake. Feed through the top screw hook, thread the hex nut on and then continue through the 2nd screw eye.

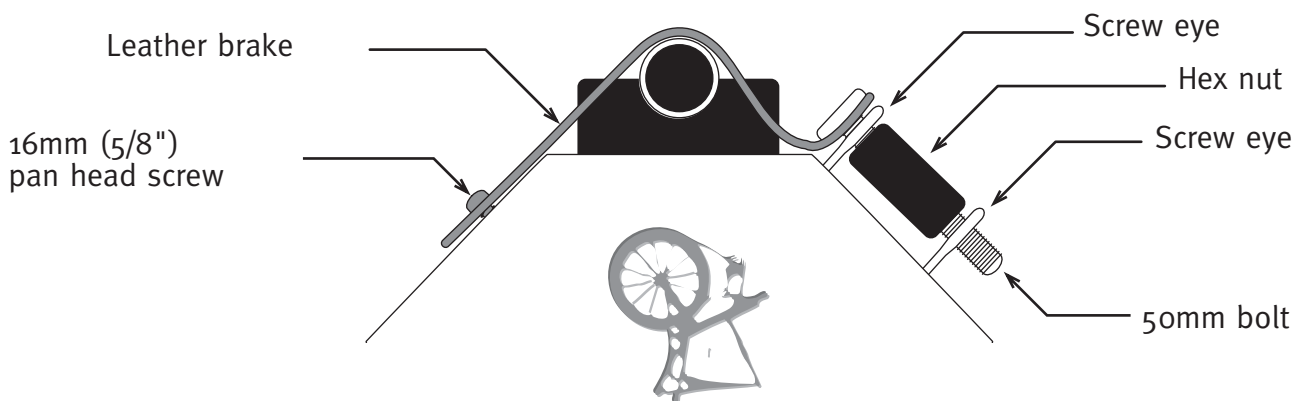

Step 19:

Threading hook assembly: thread tape through looped end of threading hook then tie ends together. This may now be hung on a convenient place on your spinning wheel for easy location.

**Remove the band from the bobbin whorl when not in use to avoid stretching.*

**Oil all bearings regularly for silent effortless spinning. We recommend Ashford spinning wheel oil for this purpose.*

