

LACE FLYER KIT FOR TRADITIONAL & TRAVELLER SINGLE DRIVE SPINNING WHEELS

TOOLS REQUIRED

⊕ screwdriver, candlewax

BEFORE COMMENCING

Read the instructions carefully and identify all parts. Note the assembly sequence.

FINISHING THE WOOD

We recommend the wood be waxed or oiled before assembly. This protects it from climatic changes and enhances its natural beauty. Use the sand paper supplied to smooth the flyer arms and bobbin ends to avoid your yarn catching. The groove in the large bobbin end should also be carefully sanded to ensure the brake band provides a smooth even tension. After sanding either use a similar finish to the rest of your spinning wheel or our natural Ashford Wax Finish.

- 1 Lace Flyer
- 3 Large Core Lace Bobbins
- 1 Maiden Upright with 3/8" ball bearing
- 1 Maiden Upright with 1/4" ball bearing
- 1 Polycord drive belt and fusing block
- 1 Cotton drive belt

PARTS LIST

- 2 Fine cotton brake band
- 1 Lightweight rubber band
- 2 Roundhead Screws
- 2 Washers
- 1 Threading hook and tape

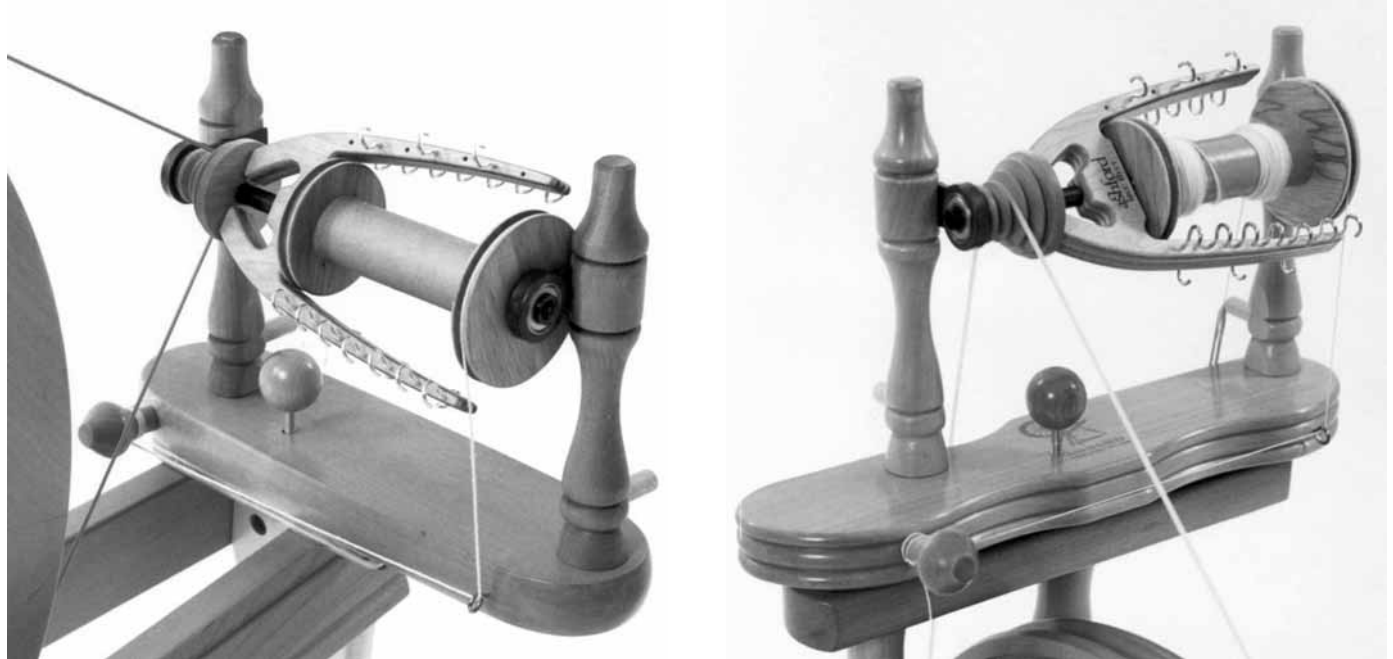

ASSEMBLY SEQUENCE

- 1) Use the screwdriver to remove the screws holding the existing maiden uprights to the maiden bar.
- 2) Remove the maiden uprights from the maiden bar.
- 3) Use the candlewax to wax the dowel ends of the new maiden uprights.
- 4) Insert the new maiden uprights into the maiden bar and secure with the round head screws and washers. **Do not overtighten** as the maiden uprights have to be twisted to enable the bobbins to be changed.
- 5) Thread the flyer hooks into the pre-drilled holes in the flyer. Note the holes are drilled right through. This enables flyer hooks to be used on both sides of the flyer. We recommend seven hooks on the orifice side and three on the opposite side but more may be used if desired. The hooks on the opposite side enable the yarn to be wrapped back and forth to reduce the drag on the yarn as illustrated. If the flyer is slightly out of balance, hooks may be added to reduce any vibration.
- 6) Lubricate the flyer shaft with Ashford Spinning Oil or similar light machinery oil. Then locate a lace bobbin on the shaft. **The bobbins need to be free running and oiled regularly.**
- 7) Twist both maiden uprights using the convenient pegs at the base. Slide the flyer and bobbin into position. Ensure the flyer bearings are at right angles to the flyer shaft.
- 8) Adjust the drive belt tension knob so the maiden bar is in its lowest position.
- 9) Check the alignment of the drive wheel with the flyer pulley. If necessary loosen the horizontal adjustment screws, realign the wheel and the groove in the pulley you are going to use and retighten.
- 10) Place the cotton drive belt around the wheel and largest pulley on the flyer. Then tie the ends with a flat or reef knot.
- 11) The cotton drive belt ensures the highest ratios are achieved. However if a slightly lower ratio is acceptable the alternative polycord drive belt will result in easier treading.

- to join the polycord drive belt place it around the wheel and largest pulley on the flyer.
 - mark the polycord where it is just the right length without stretching it. Do not make it tight.
 - cut off the excess polycord with a razor blade, sharp knife or scissors and save it for future repairs or adjustment.
 - before joining place the cord back around the wheel.
 - hold the two ends close to the base of the flame of a candle until the ends start to melt. The flame at the base is cleaner and results in a clear joint.
 - then quickly press the ends tightly together in the groove in the wooden fusing block. Hold firmly for about 30 seconds or until the polycord has cooled.
 - use a razor blade or nail clippers to trim off the excess material around the joint.
 - adjust the tension knob so the polycord tension is as loose as possible without actually slipping.
- 12) Remove the existing brake band from the tension knob and replace it with the new fine cotton band. Locate it over the large bobbin pulley and tie to the lightweight rubber band. Twist the tension knob to obtain the desired brake tension. Generally for best results the rubber band should only just start to stretch.

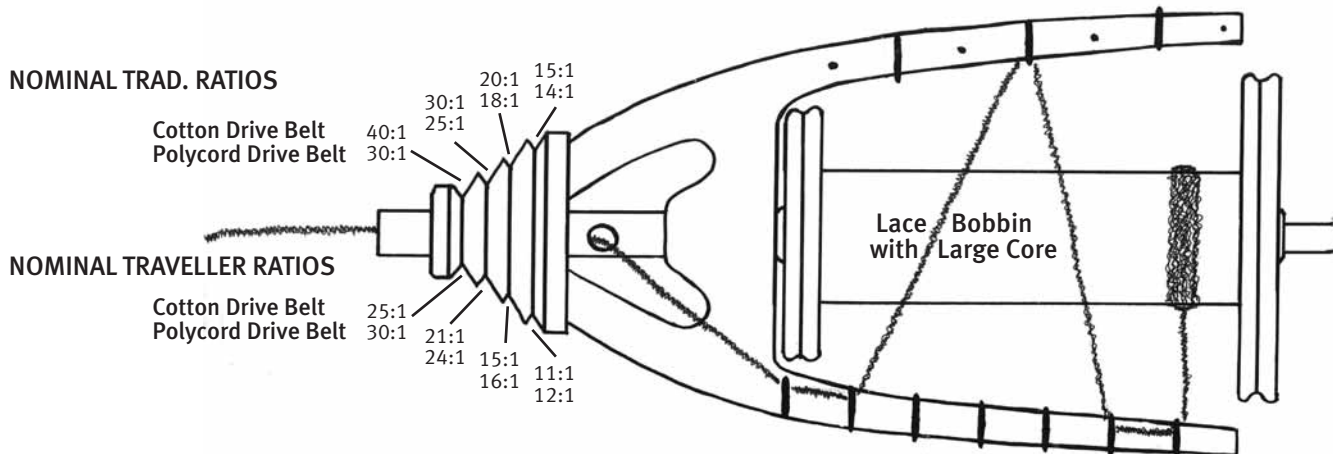

Special features of your new Lace Flyer

You can spin - Cotton, Angora, wool, silk and other exotic fibres into fine high twist

- Large core bobbin ensures gentle take up of the yarn
- Maiden uprights with ball bearings inhibit vibration and makes spinning smooth and relaxing
- Choice of two drive bands - stretchy 2 mm polycord or light high-twist cotton

Flyer ratios can vary between wheels and drive bands

Traditional Spinning Wheel		Traveller Spinning Wheel	
Polycord	Cotton	Polycord	Cotton
30:1	40:1	25:1	30:1
25:1	30:1	20:1	24:1
18:1	20:1	15:1	16:1
14:1	15:1	11:1	12:1

- Closer flyer hooks
- Smaller flyer is lightweight, has less wind resistance and is easy to treadle faster
- The grooves in the bobbin have been checked for smoothness. In the unlikely event of roughness occurring smooth gently with sandpaper provided.
- Tension rubber band will make sure very light tension adjustment is possible.
- Brake band - the fine mercerised cotton band will help you respond to the characteristics of the fibre you spin. Perfect for super-light tension required for super-fine spinning.

FINE SPINNING HINTS

Tension - Take time to adjust the tension to suit your spinning.

Ratios - Choose the ratio to suit your project. If the yarn is prepared thoroughly then a high ratio will be easy to use. When using a shorter fibre for the first time start on the slower drive ratio. Later move to a faster ratio.

Many factors determine the correct ratio for your purpose:

- the fibre you use
- the yarn you require
- how fast you treadle
- if you want to take it easy or need to quickly finish a project
- the preparation of the fibre for spinning

PREPARATION OF FIBRE

Prepare the fibre according to the yarn you require. For beginners a prepared combed top or carded sliver makes learning to fine spin easier. Try the long draw method when spinning shorter fibres, letting the twist gather the fibres from your hand. For longer fibres try spinning from the fold this will let air into the yarn.

MERINO SLIVER KIT

We have included some fine merino combed wool top - 22 micron in the kit. Enough to spin the yarn for a first small project. Try knitting Margaret Stove's beautiful Fine Lace Scarf - pattern included. The correct yarn for this pattern is in the range of 30 wraps/inch (2.5 cm).

Ashford Handicrafts Ltd.
 Factory and Showroom: 415 West Street,
 PO Box 474, Ashburton, New Zealand
 Telephone 64 3 308 9087
 Facsimile 64 3 308 8664
 Email: sales@ashford.co.nz
 Internet: www.ashford.co.nz

Ashford Guarantee
 Thank you for purchasing this Ashford product. In the unlikely event there is any fault in manufacture we will replace the item. To validate our guarantee please visit our website or write to us.
 Please also join our Ashford Club for the Wheel Magazine, competitions and more at www.ashfordclub.co.nz