

Assembly Instructions For The Ashford 16 Shaft Table Loom

610 mm / 24"



TOOLS



Screwdriver



CandleWax

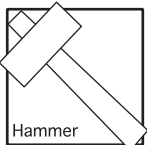

Hammer

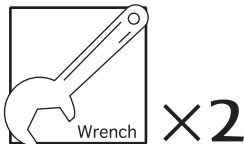

Wrench **x2**

In the kit



Hint 1

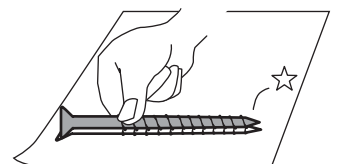
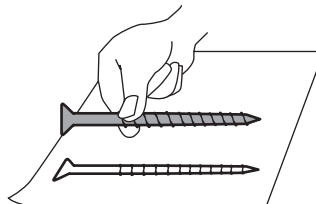

Hint 2

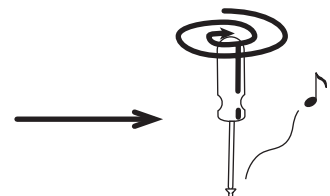
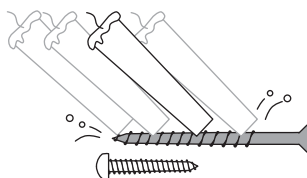

These instructions are based on the Ashford Table Loom Eight shaft.
Please note: The 16 Shaft castle is twice as wide as the 8 shaft.

1

!Check

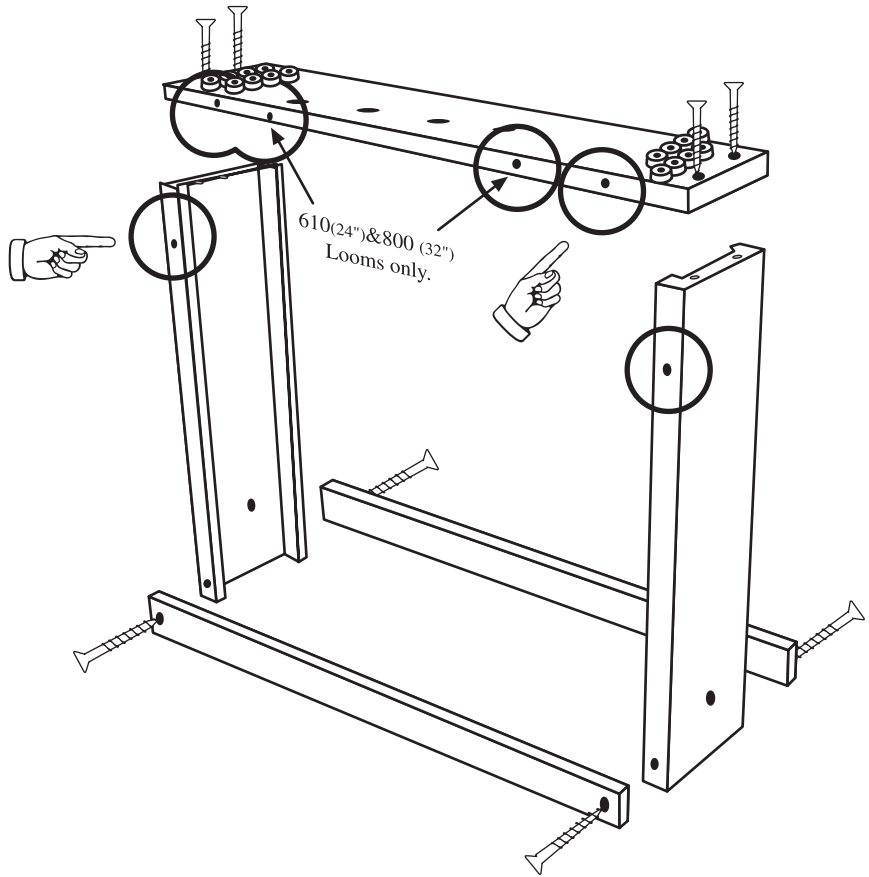
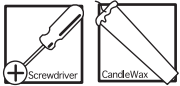
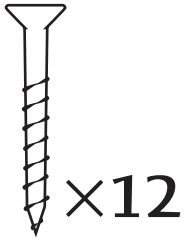

2

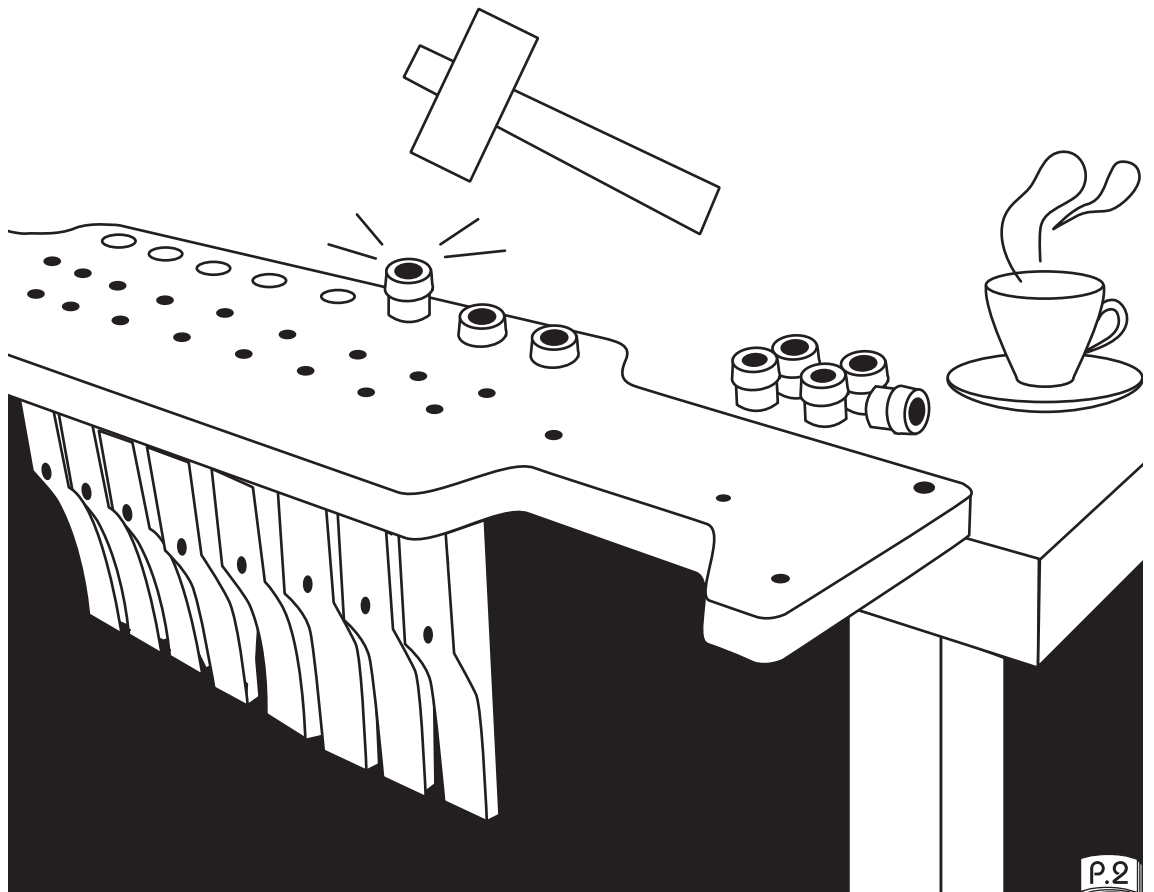
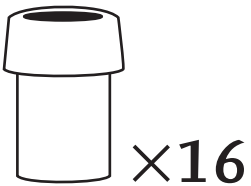

The Ashford Table Loom Eight shaft
The 16 Shaft has 16 levers

3

- ×4
410 mm (16") Loom
- ×6
610 (24") & 800 mm (32")
Looms



×2

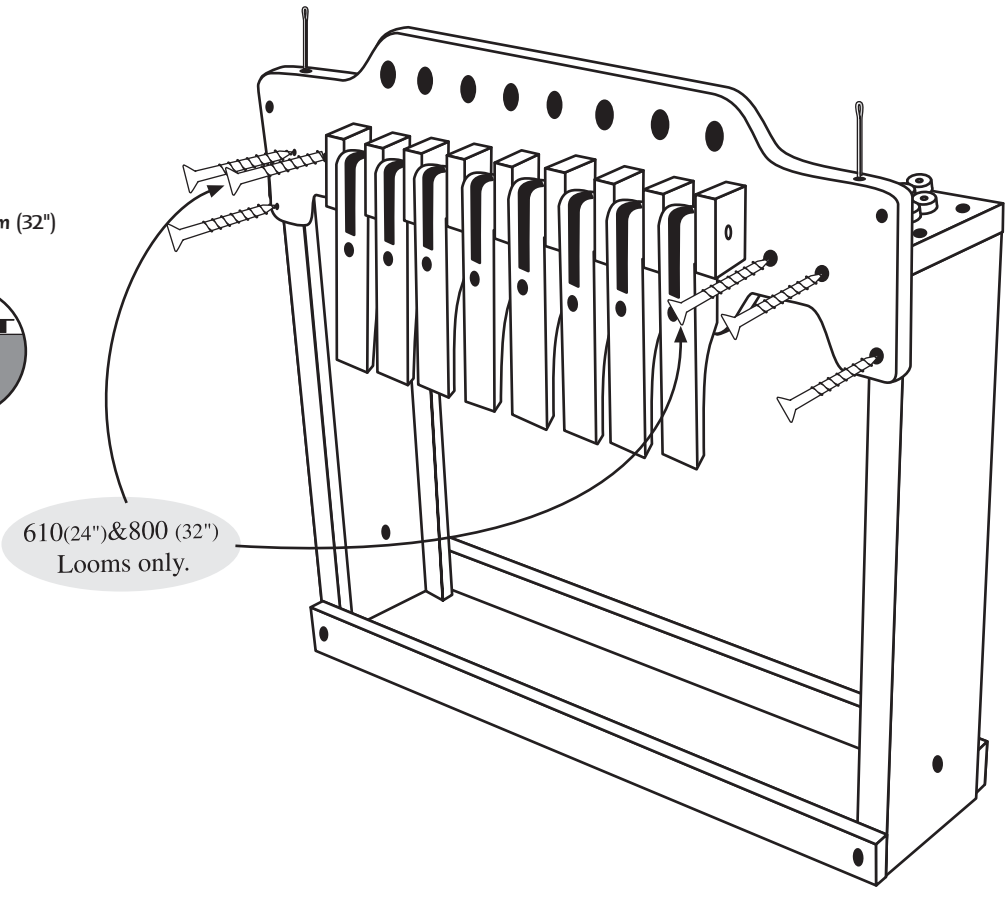

610(24")&800 (32")
Looms only.

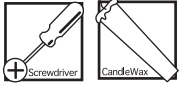

The Ashford Table Loom Eight shaft
The 16 Shaft has longer sides

4

!Check

- ×8

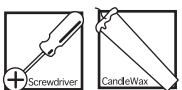
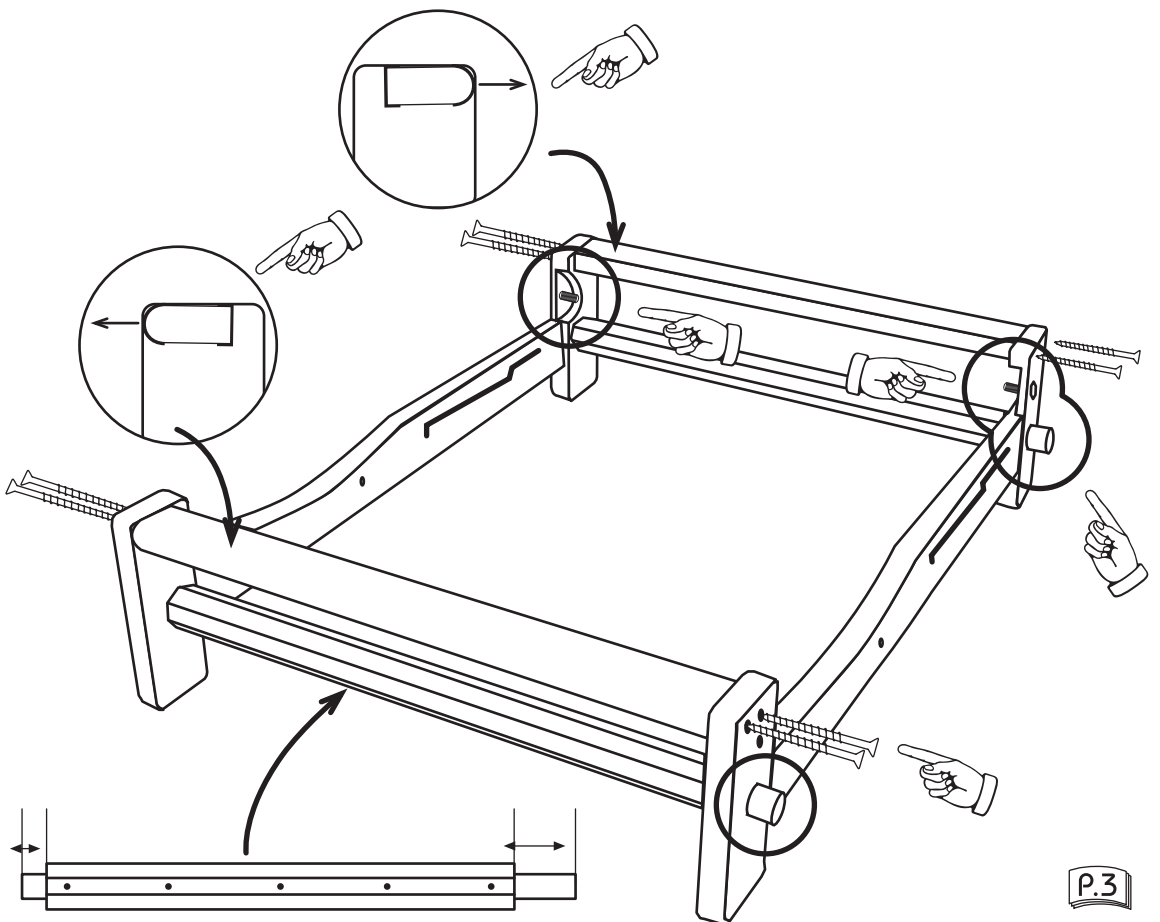

The Ashford Table Loom Eight shaft
The 16 Shaft has longer sides

5

!Check

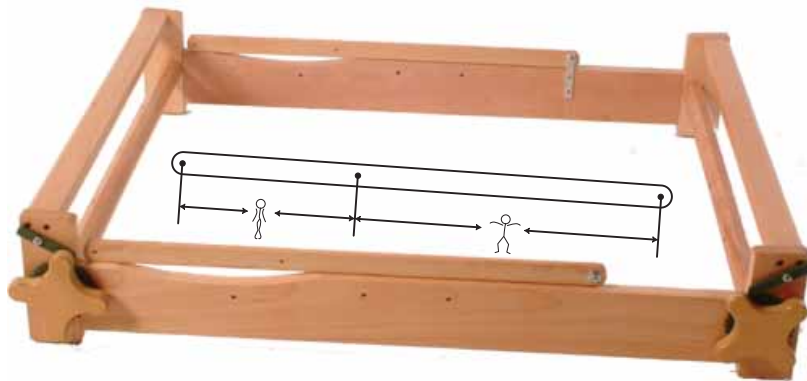
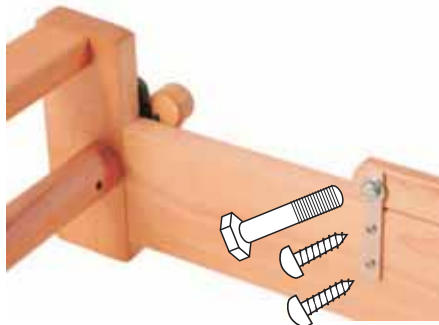
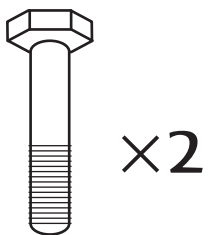
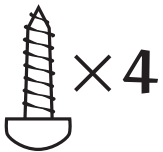
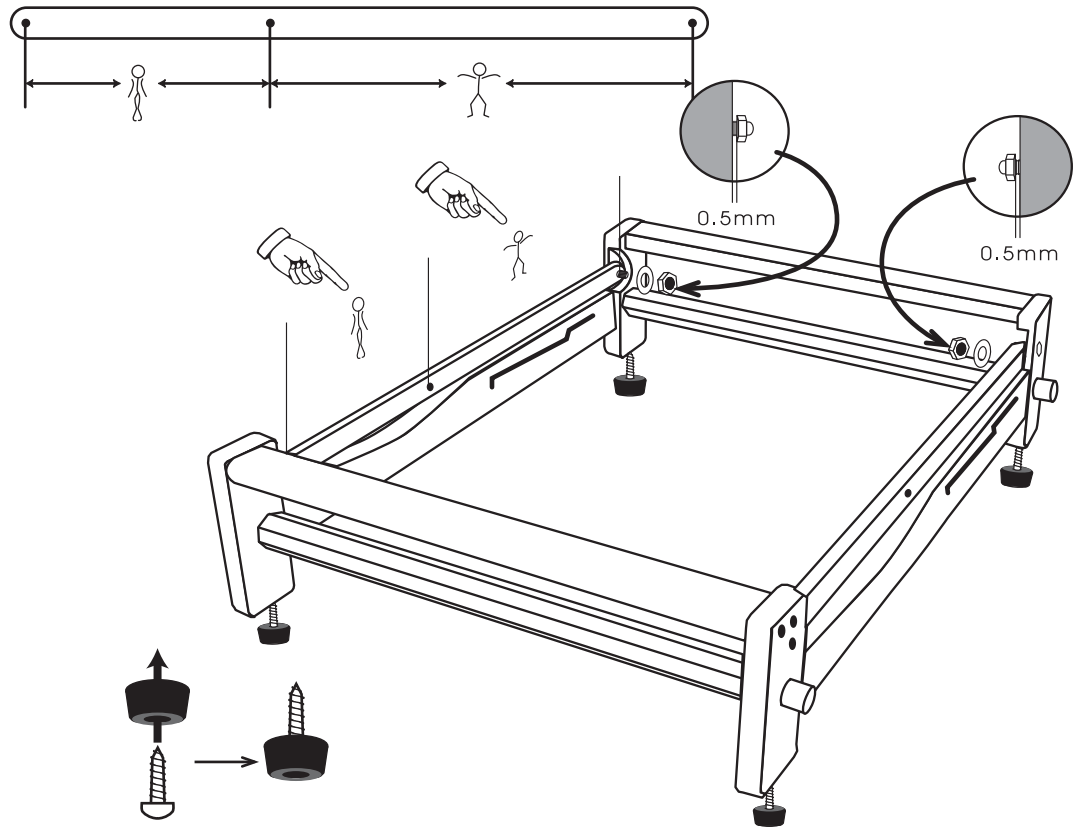
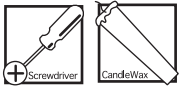
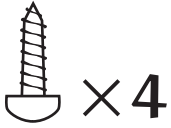

The Ashford Table Loom Eight shaft
The 16 Shaft has longer sides

6

!Check

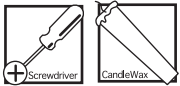
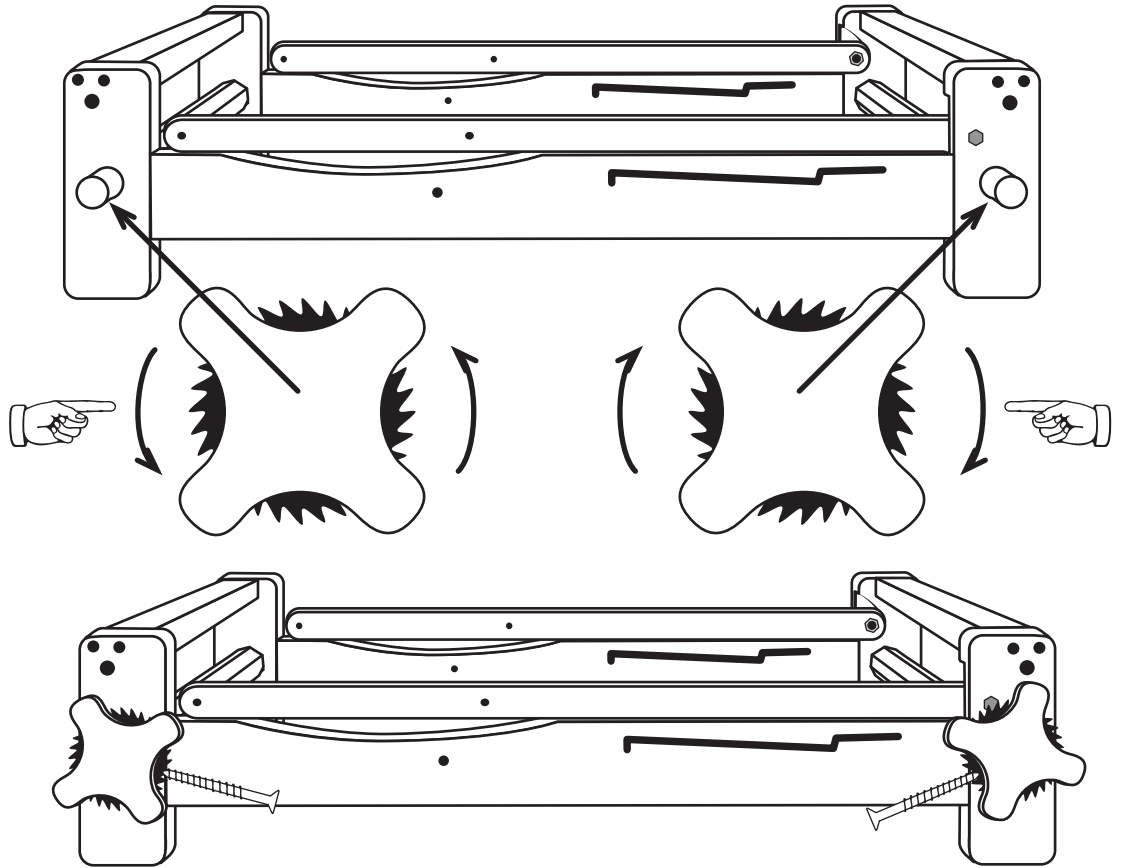
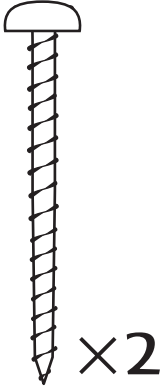

7

!Check

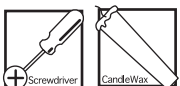
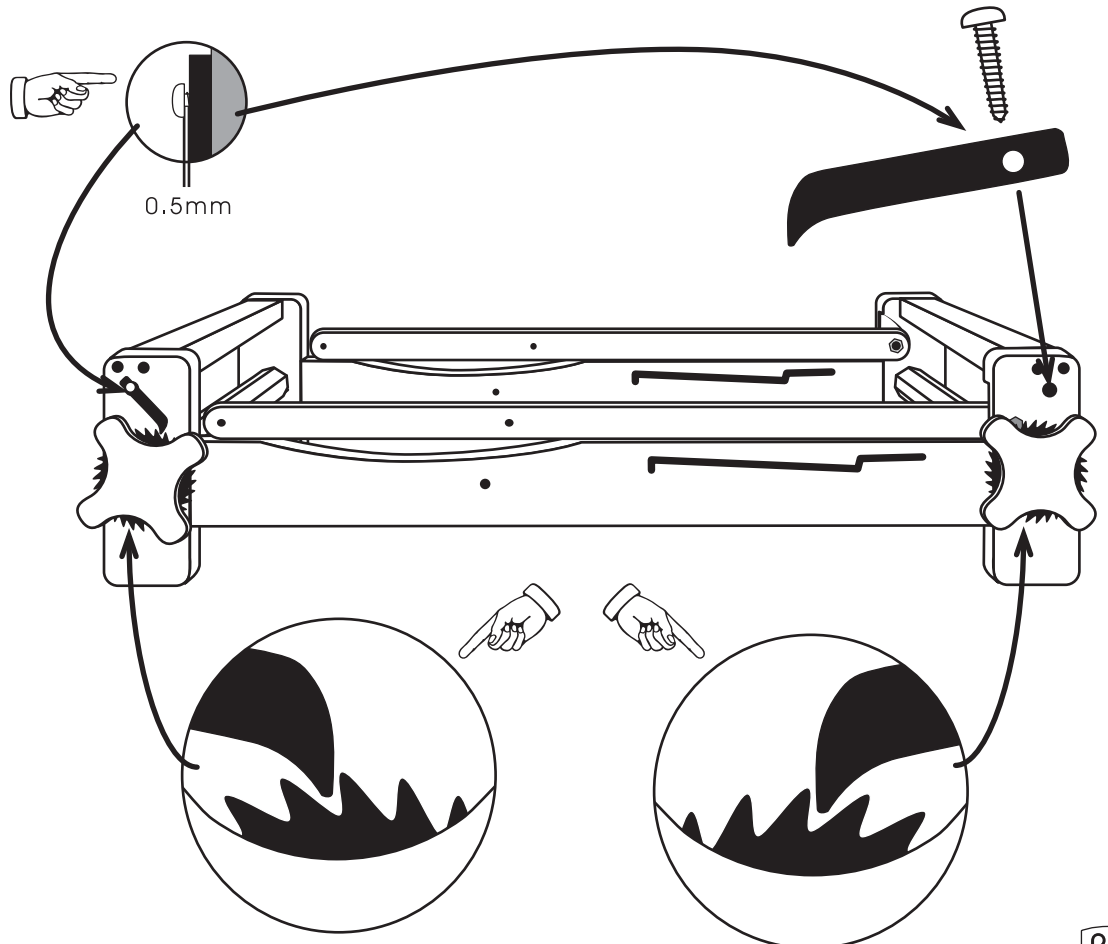
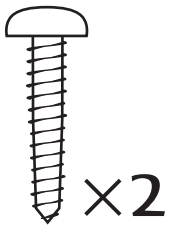

The Ashford Table Loom Eight shaft
The 16 Shaft loom has 16 shafts

8

!Check

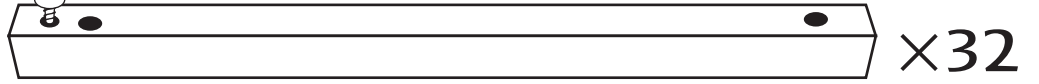
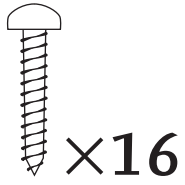

9

!Check

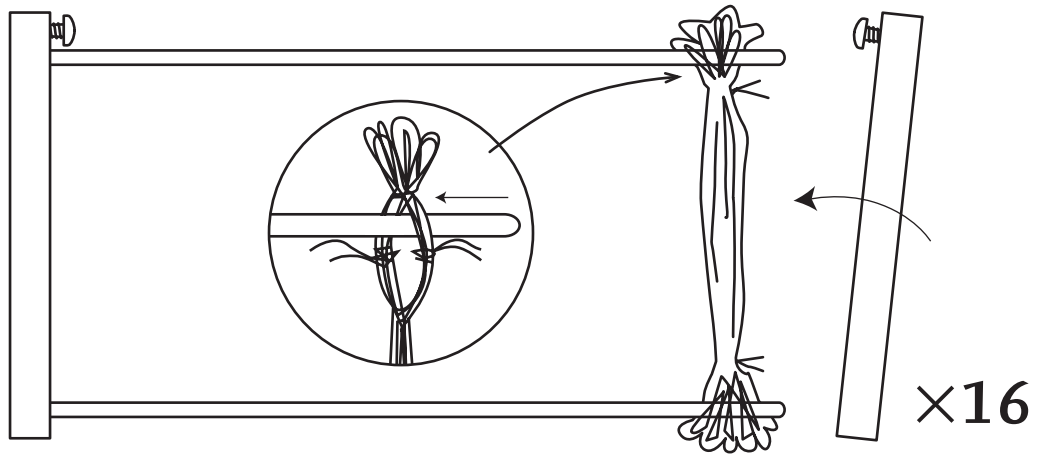

10

!Check

The Ashford Table Loom Eight shaft
The 16 Shaft loom has 16 Shafts

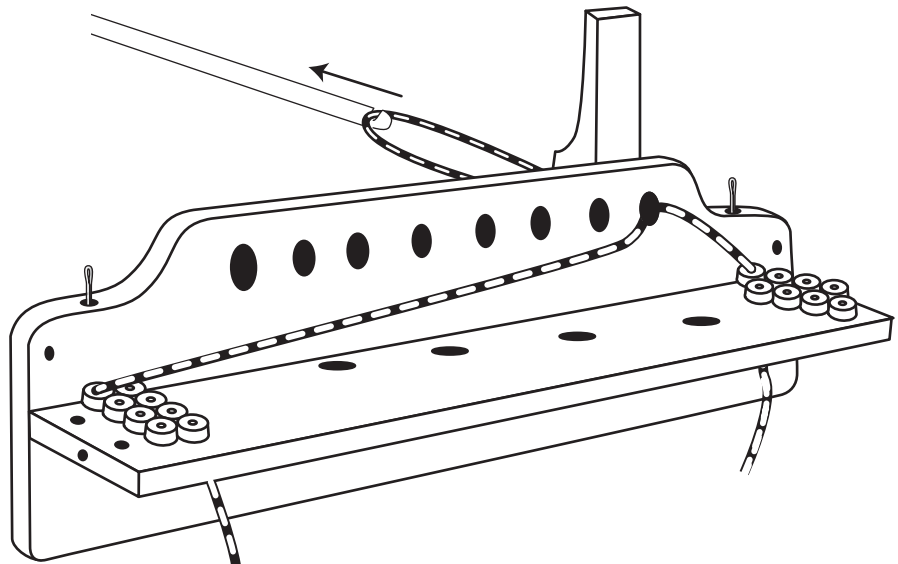
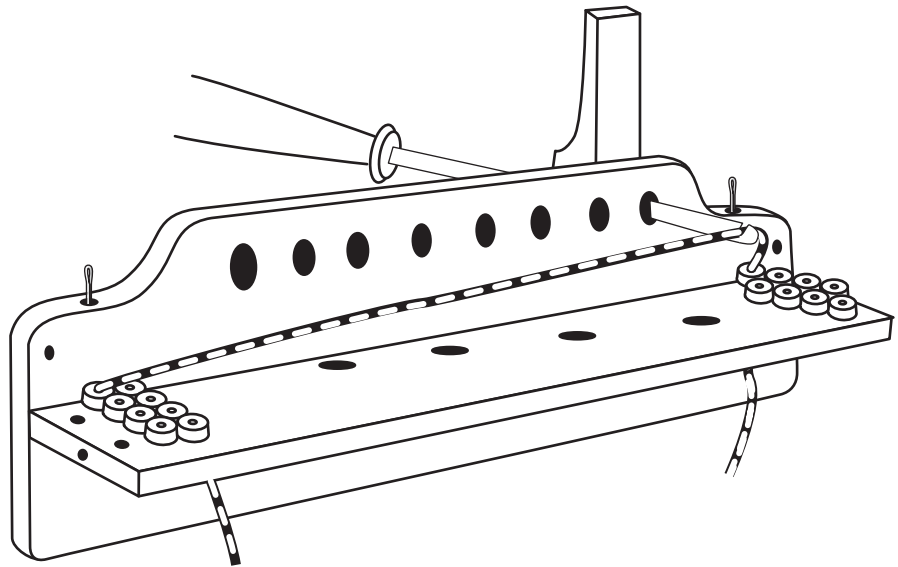
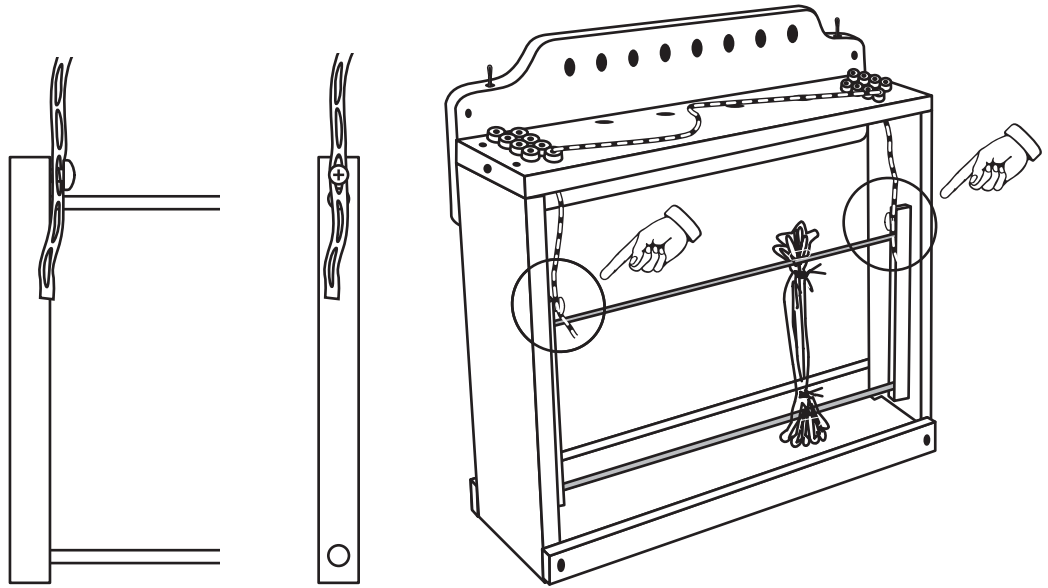

10 Cont.

The Ashford Table Loom Eight shaft
The 16 Shaft loom has 16 Shafts

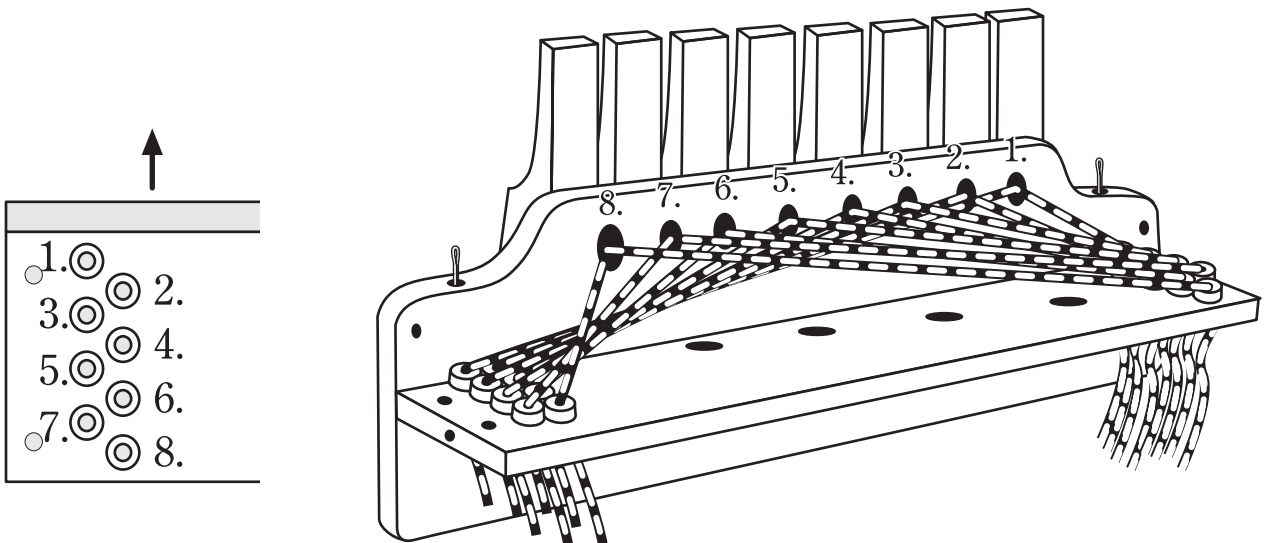
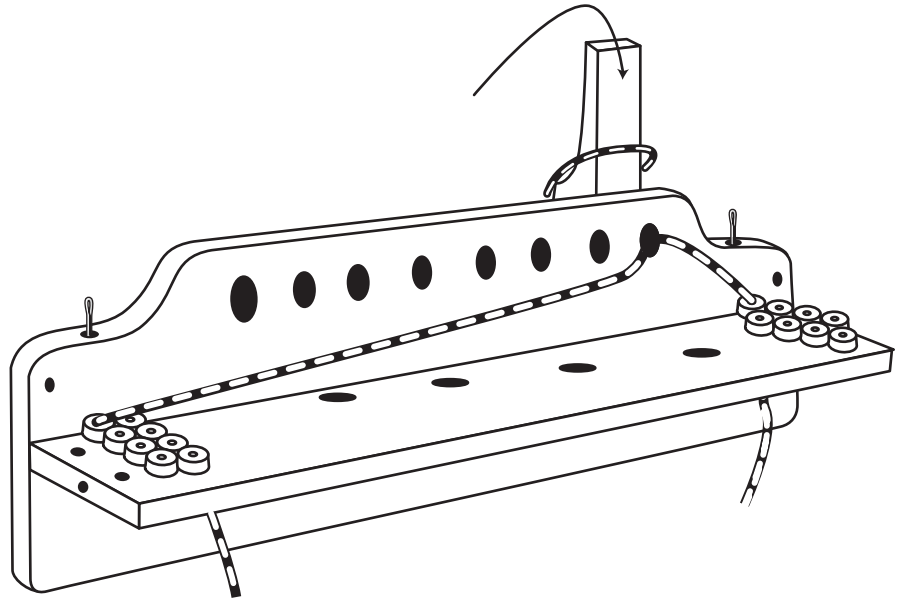
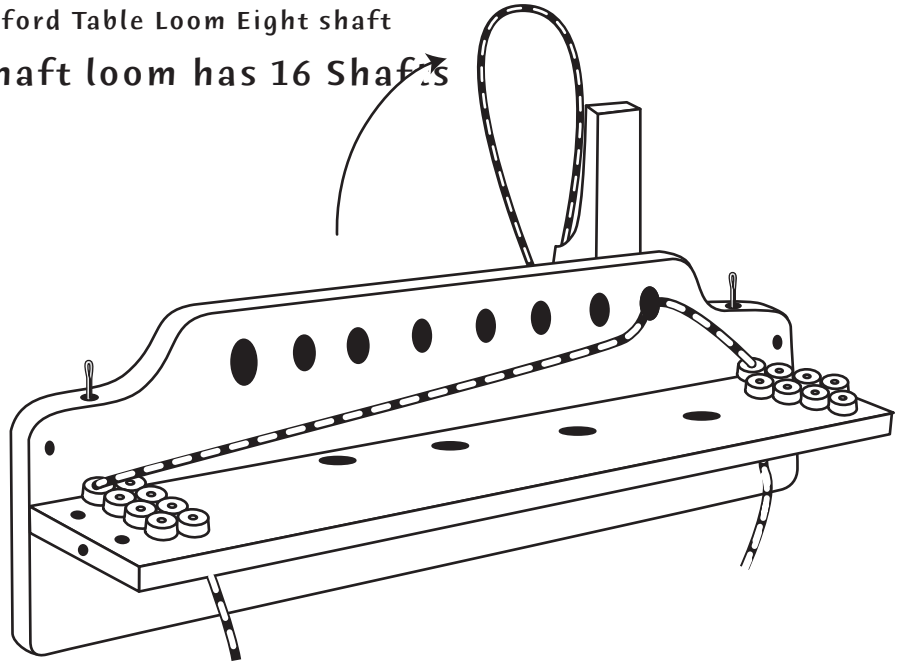

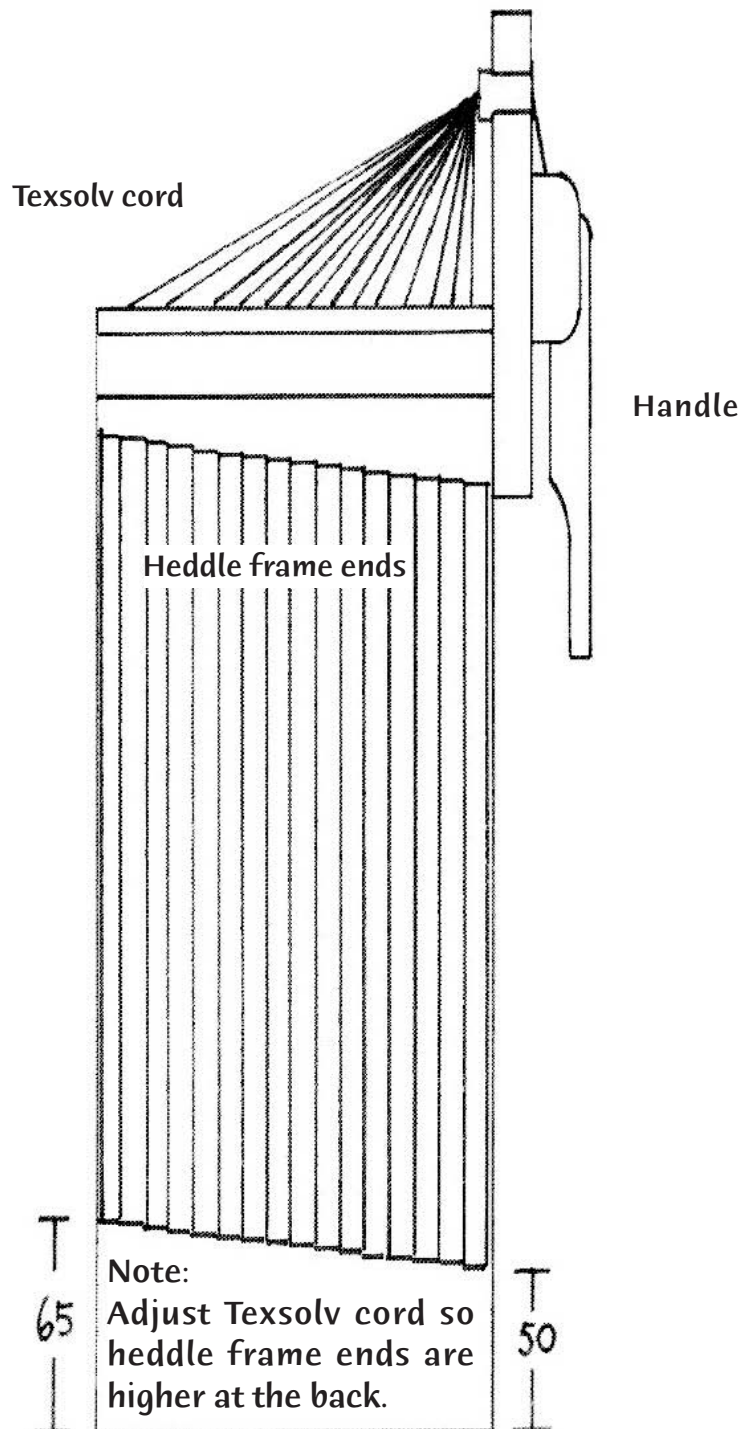

11

The Ashford Table Loom Eight shaft
The 16 Shaft has 2 bolts either side

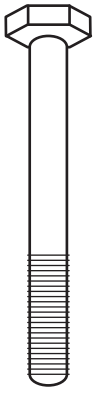

×4

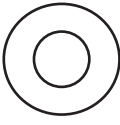

×4

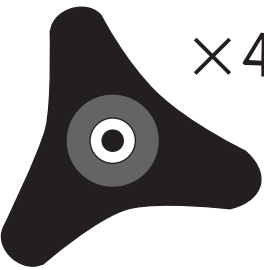

×4

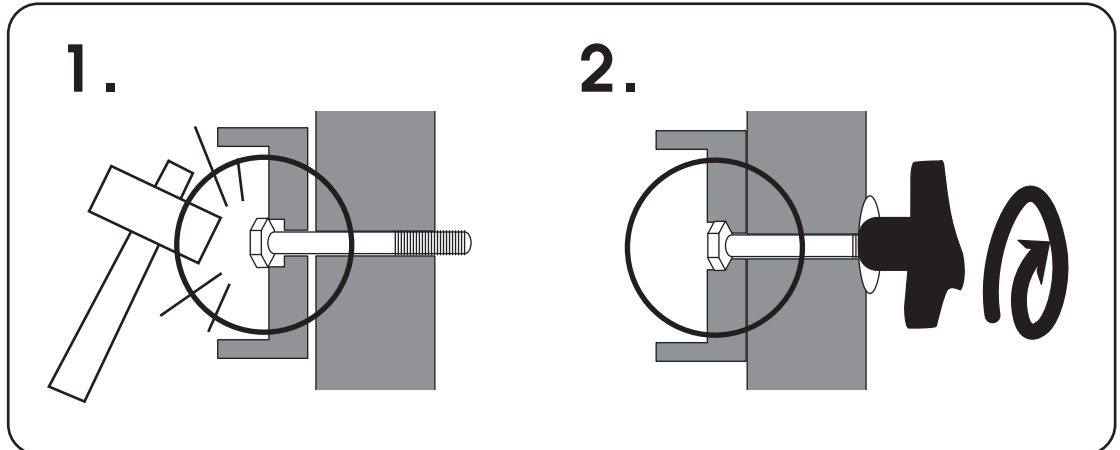
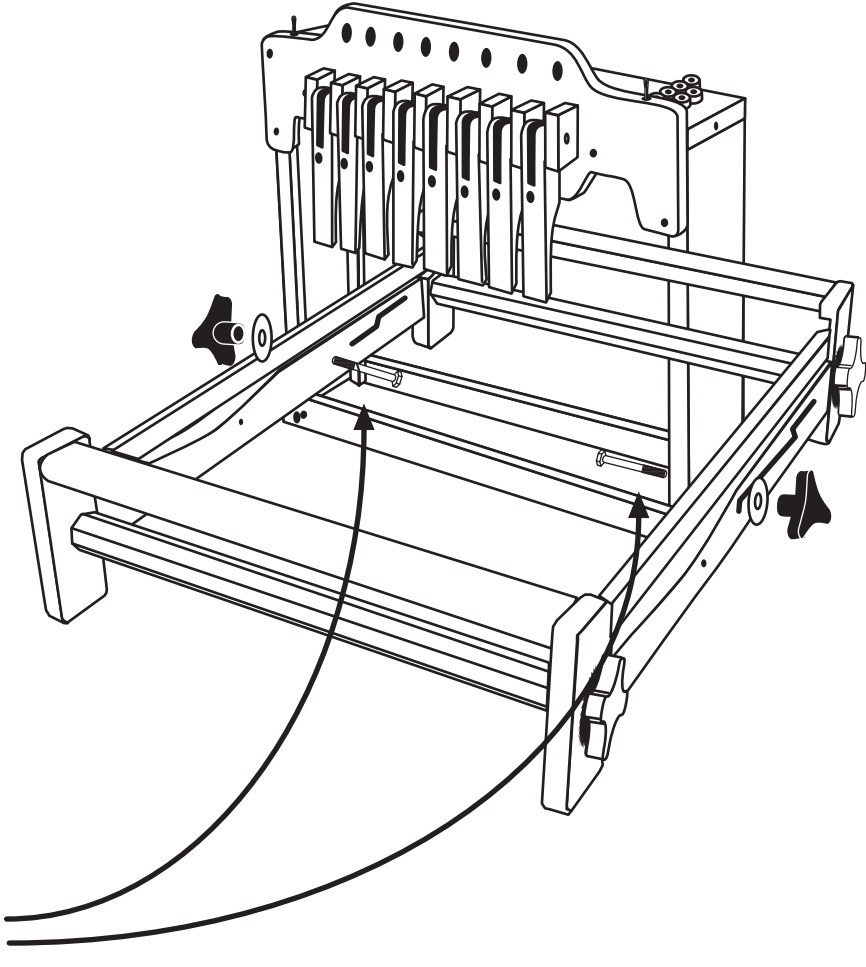

12

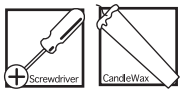
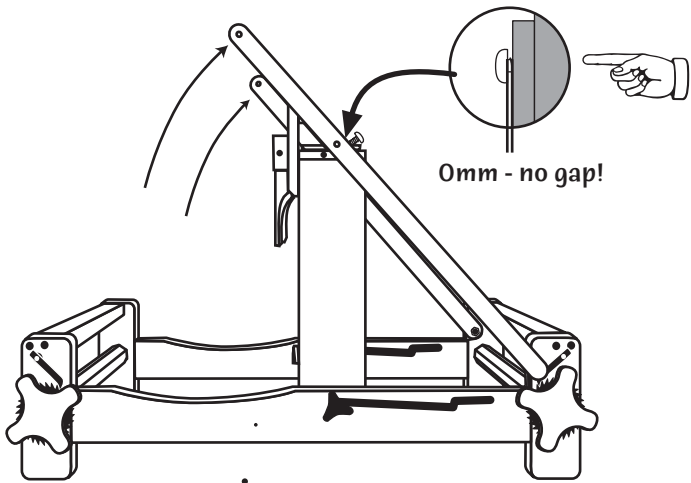

Screwdriver

CandleWax

The Ashford Table Loom Eight shaft and 16 Shaft

13

!Check

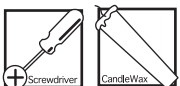
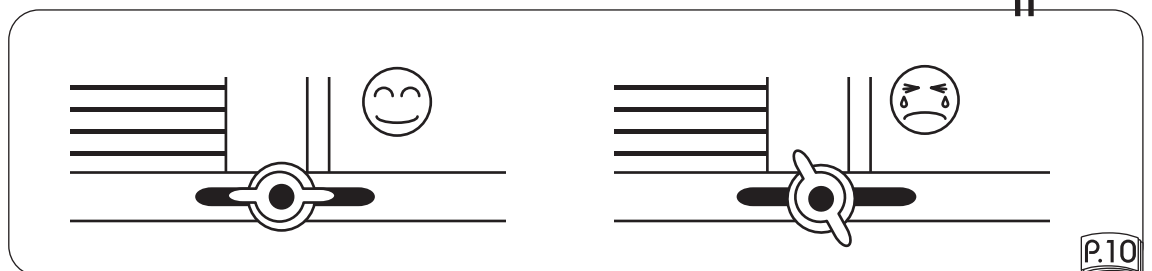
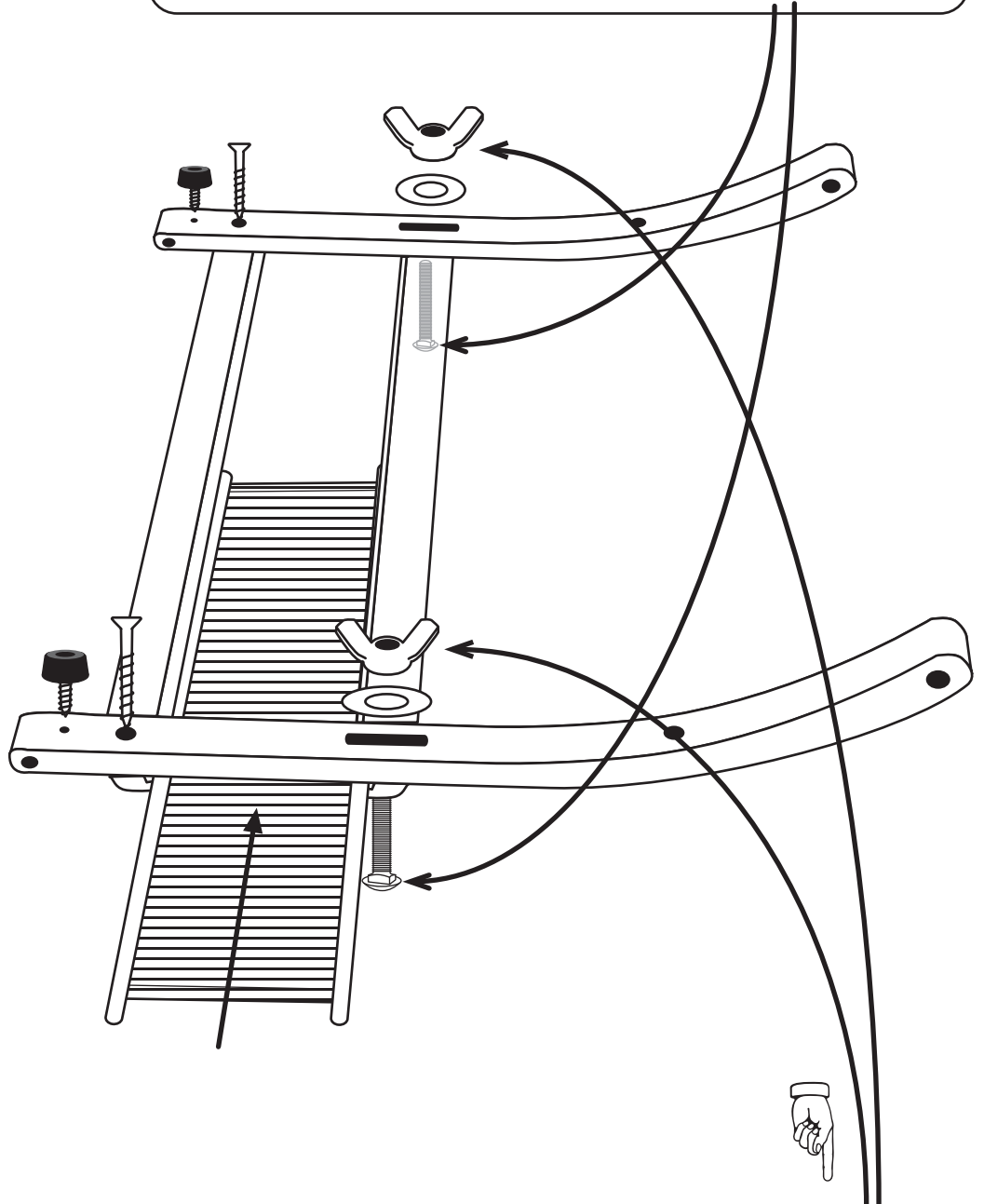
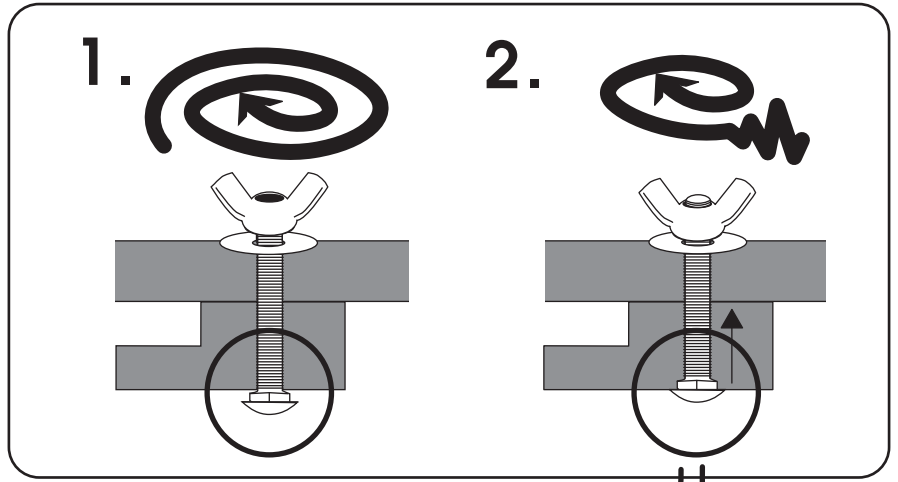
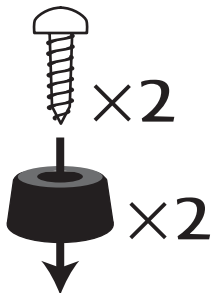
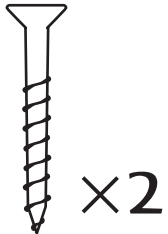
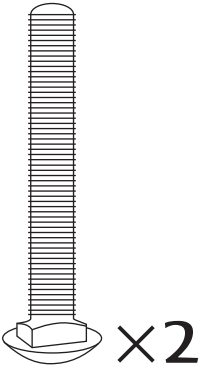
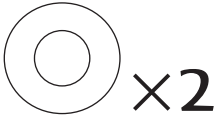
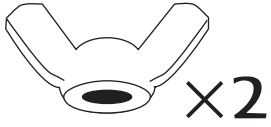

14

The Ashford Table Loom Eight shaft and 16 Shaft

!Check

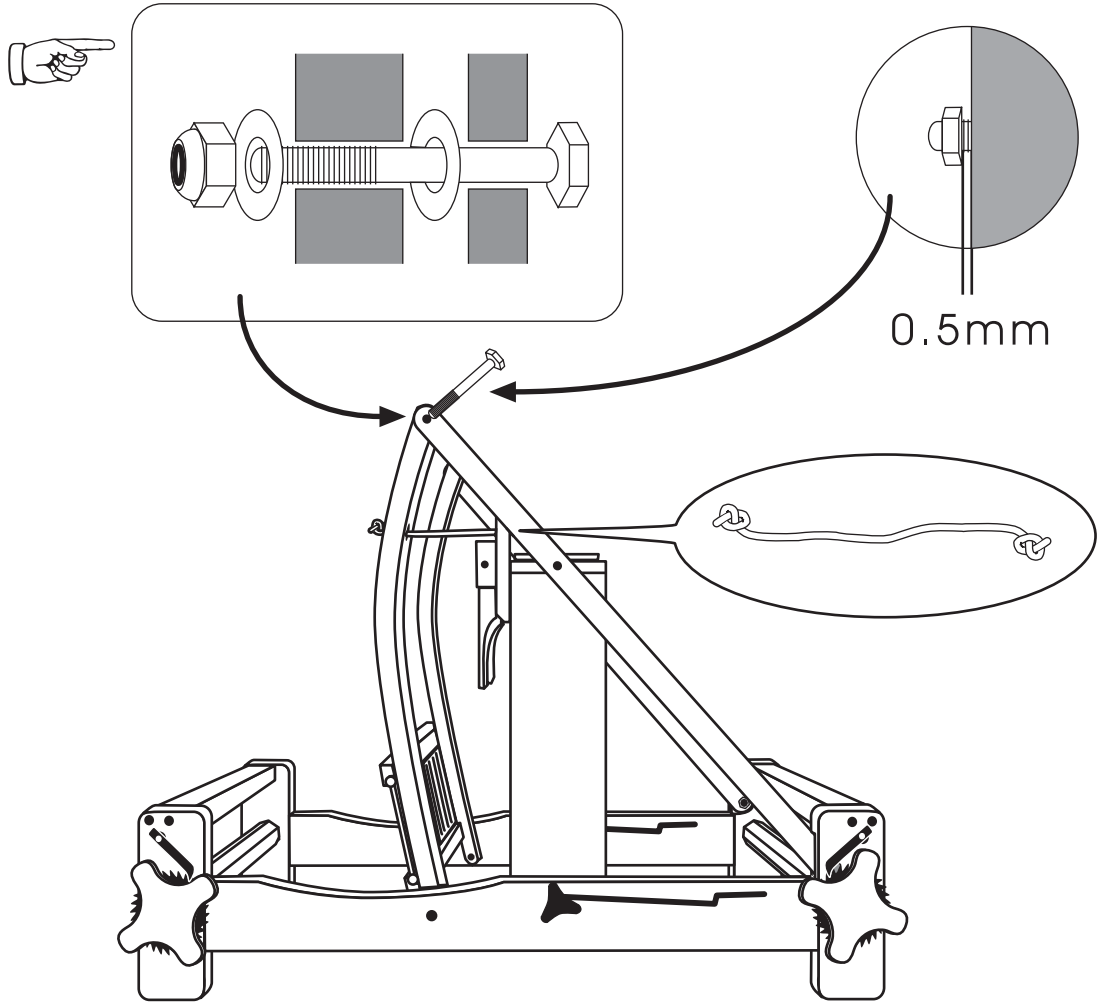
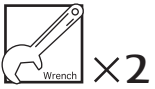
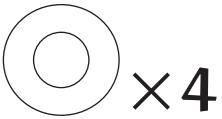
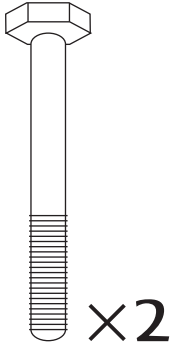

Meaning of Symbols

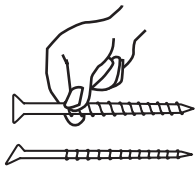

Real scale Instructions

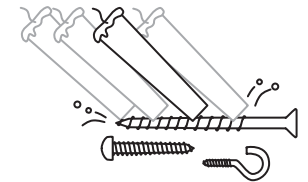
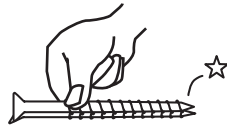

Wax the screws and hooks



Check the directions or shapes carefully



Right



Wrong



Really tight

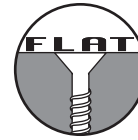

Screw Down level

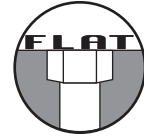

Assembly Instructions for The Ashford Table Loom - Sixteen Shaft

- Step 1 Assemble the castle with 12 screws.
- Step 2 Rest the castle front on a table edge for support. Tap the 16 nylon guides into the cord holes from the back.
- Step 3 Screw the castle front to the castle. Locate the beater pins into the holes in the castle front.
- Step 4 Place the rollers into the holes in the loom sides. With the long ends of roller on the right hand side (if you are left handed you can put the long ends on the left hand side).
Screw the front and back beams into place. Check the rounded edge of the beams face out.
- Step 5 Attach the rubber feet and the metal support brackets to the sides. Then attach the support arms to the brackets after checking they are the correct way around.
- Step 6 Place the handles onto the roller ends. After checking the direction of the ratchet teeth, secure with screws.
- Step 7 Attach the pawls with screws. Leave a 0.5 mm (1/32" inch) gap so the pawls can move freely.
- Step 8 Thread the screws into the heddle frame ends but leave a 5mm (1/4" inch) gap to loop the texsolv nylon cord over.
- Step 9 Push the metal bars into one end, slide a bundle of texsolv heddles over the bars and push the other end in place.
- Step 10 Slide the heddle frames into the castle. Then attach the lengths of texsolv cord to the heddle frames and levers in the sequence as shown, It is important to adjust the heddle frames so they slope down from back to front as illustrated to achieve the maximum shed.
- Step 11 Place the castle inside the frame and attach with 2 bolts, washers and tri knobs on each side. Tap the bolts into the inside of the castle. Make sure the bolt heads are level with the castle side.
- Step 12 Lift the support arms up and attach them to castle sides with screws.
- Step 13 Beater frame assembly.
- Step 14 Attach beater frame to the support arms. Leave 0.5 mm (1/32" inch) gap so the beater can swing freely. NOTE: If the beater frame rubs against the loom sides loosen the wing nuts and retighten.
Stretchy cord - knot the cord at one end, slide through the hole in beater support rail, the hole in the castle front and knot the other end.
Now follow the easy step by step warping guide to warp and weave your first woven sample!