

RIGID HEDDLE LOOM STAND

40cm (16"), 60cm (24"), 80cm (32"), 120cm (48")

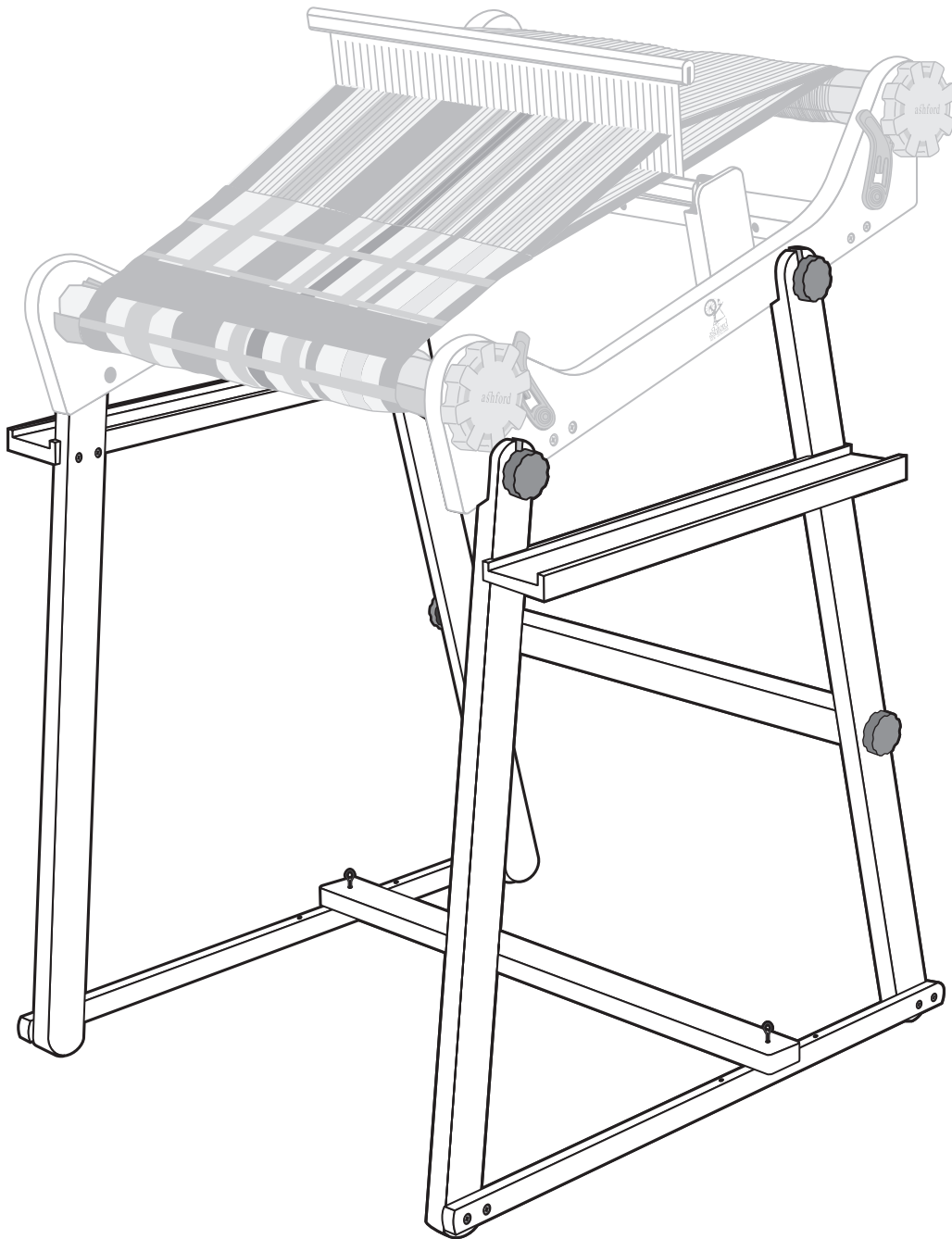

RHLS20042018V4

ASSEMBLY INSTRUCTIONS FOR THE ASHFORD RIGID HEDDLE LOOM STAND

Before commencing, please read these instructions completely, identify the parts and note the assembly sequence.

Remove any sharp corners or edges and smooth the surface of the wood with the sand paper provided. We recommend that the wood surfaces be waxed or sealed before assembly. This protects the kiln dried wood from the climatic changes and prevents it getting dirty or stained. The Silver Beech tree is a native of New Zealand and has a lovely variety of colour and grain. For a silky smooth matt finish, use the Ashford Finishing Wax to enhance the natural colours and character of this timber.

If you are assembling on a table, we recommend you protect the surface with a towel, blanket or

cardboard.

For older models: If your Rigid Heddle Loom does not have holes in the sides, mark the holes as shown and drill them with a 6mm (1/4") bit.

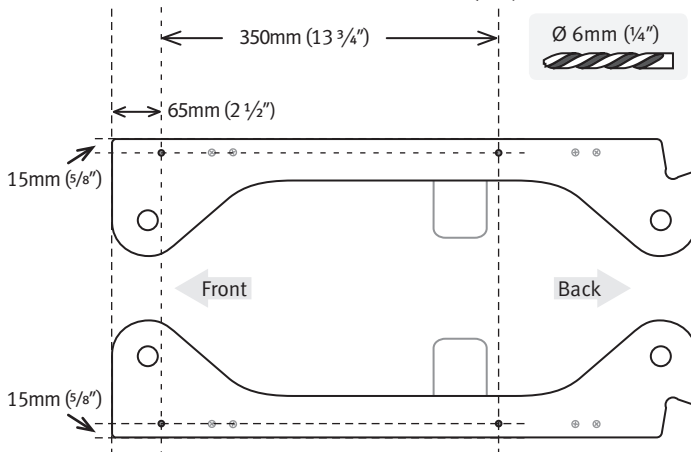

Tools Required

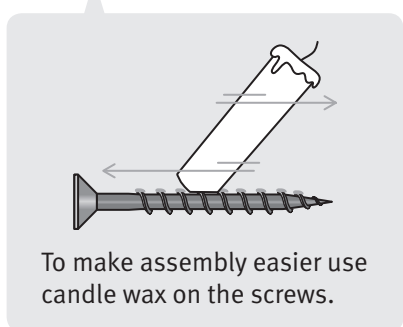

Hardware List

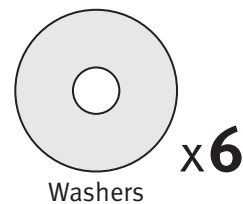
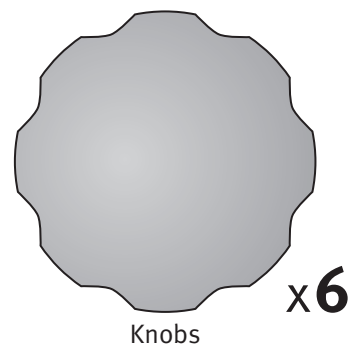
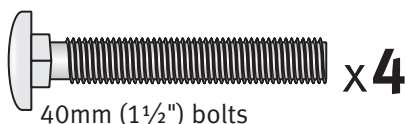
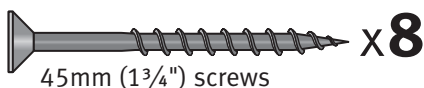
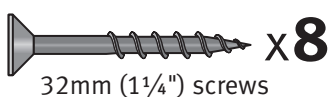

More Information



How-to videos on You Tube
Watch our how-to videos on You Tube.
www.youtube.com/user/AshfordHandicrafts



Facebook
Join us on facebook.
www.facebook.com/ashford.wheels.looms

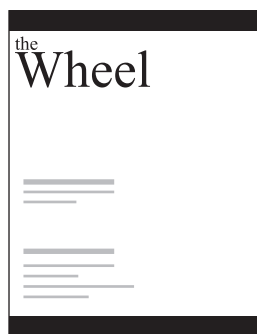

The Wheel Magazine
Ashford's annual fibrecraft magazine. Spinning, weaving, felting, dyeing and knitting projects, patterns and articles from around the world. To receive the premium version delivered to you, subscribe at:
www.ashford.co.nz/subscribe

Parts List

Left Side Parts

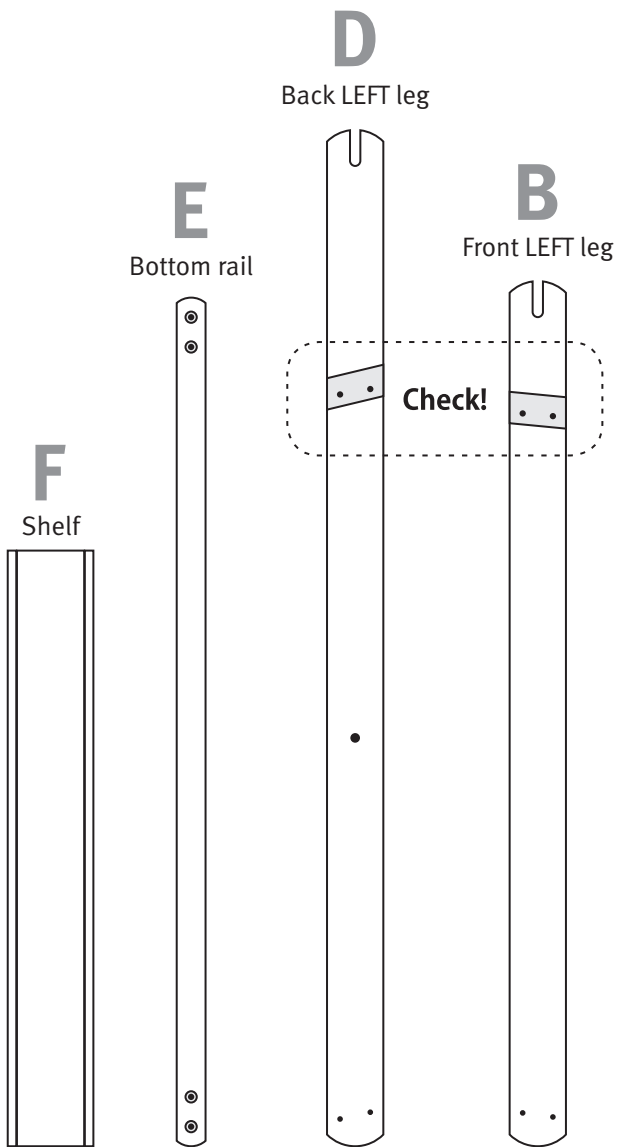

Check the shape of each groove.

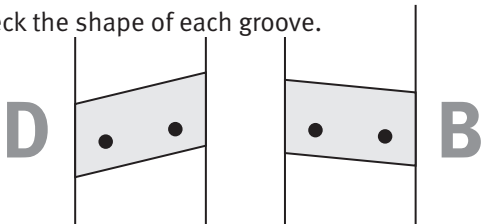

Right Side Parts

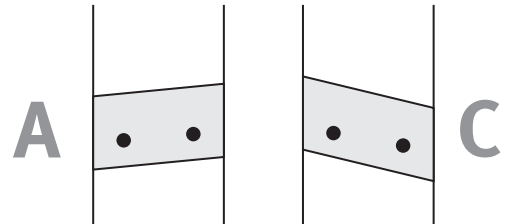
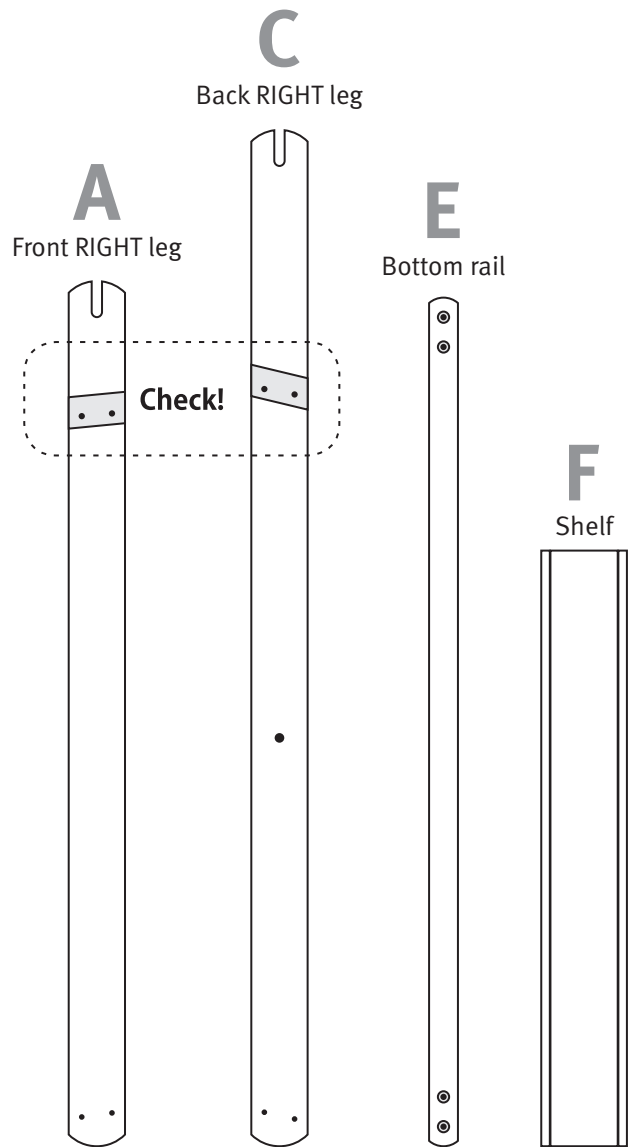

Middle Parts

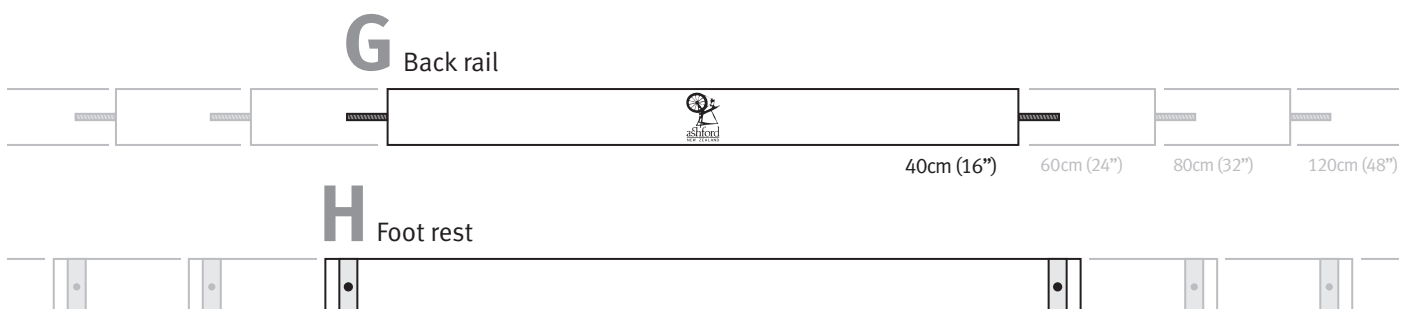

1

Align parts, Insert F to grooves on the each leg, Secure F with with 45mm (1 3/4") screws.

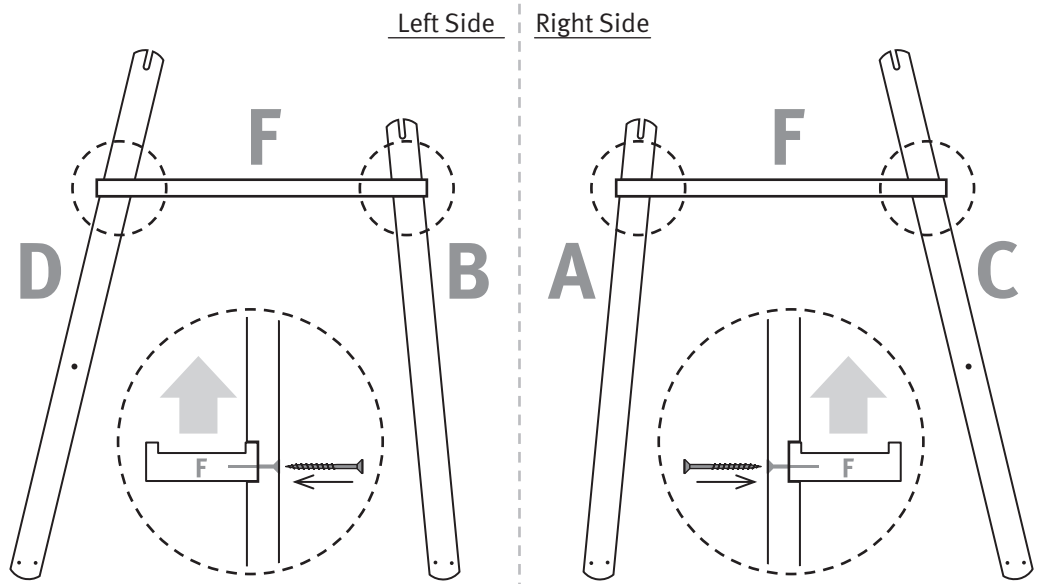
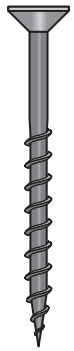

2

Make sure the direction of E, Secure E with 32mm (1 1/4") screws.

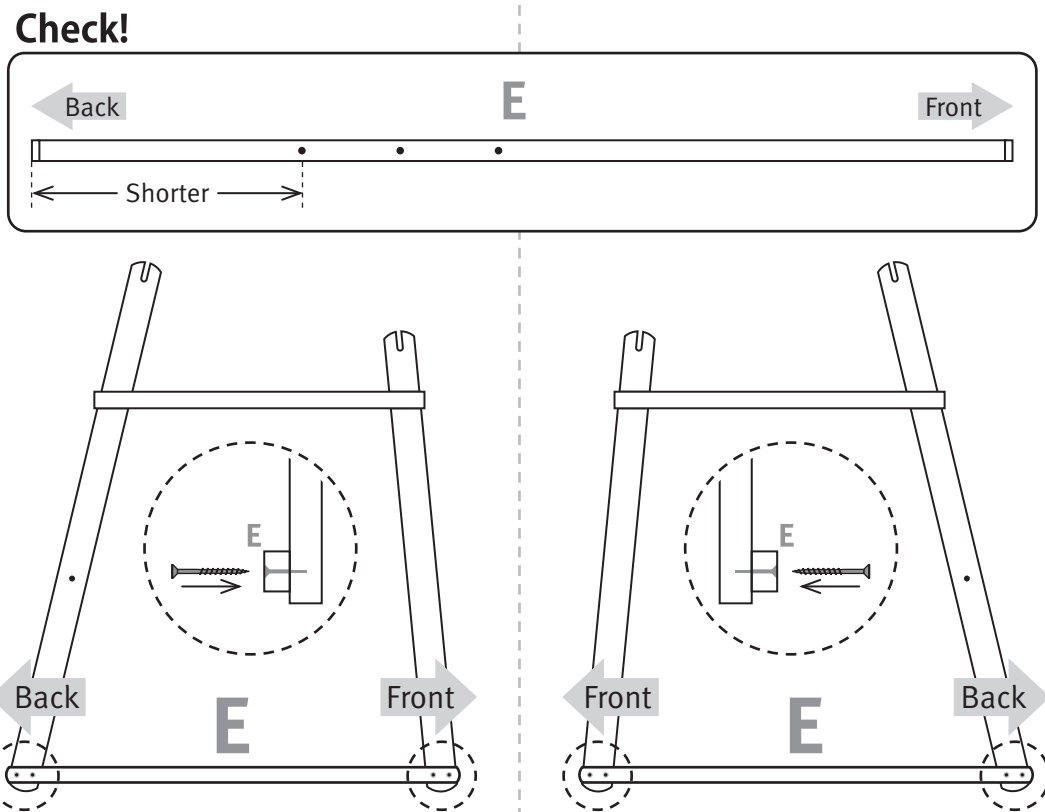
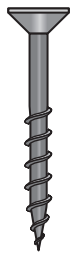

3

Connect Right side and Left side, Washers + Knobs

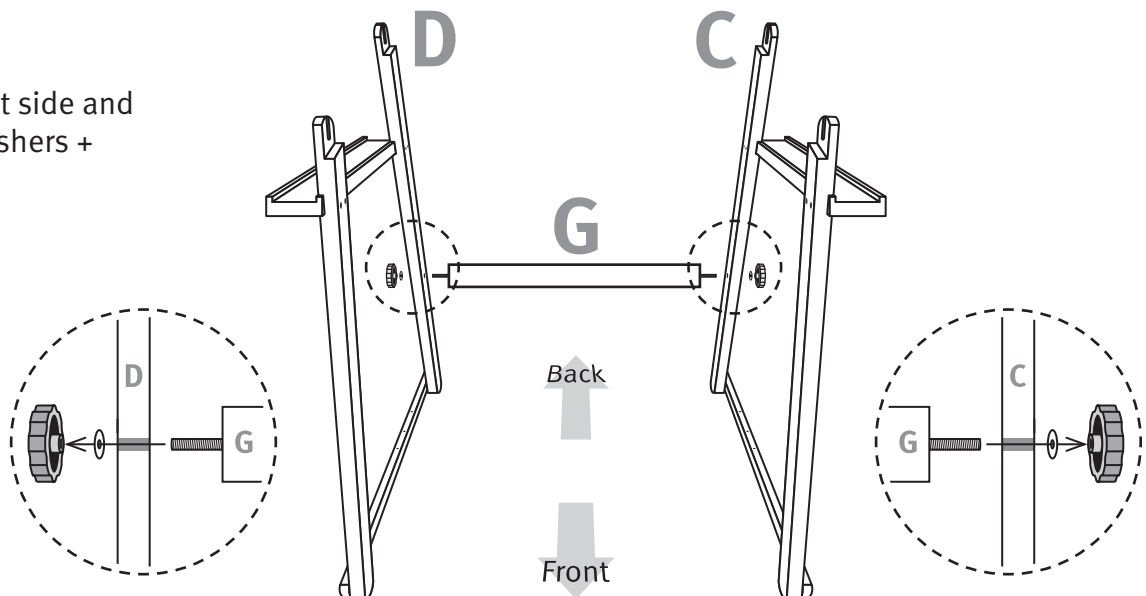

4

Attach H
Pins

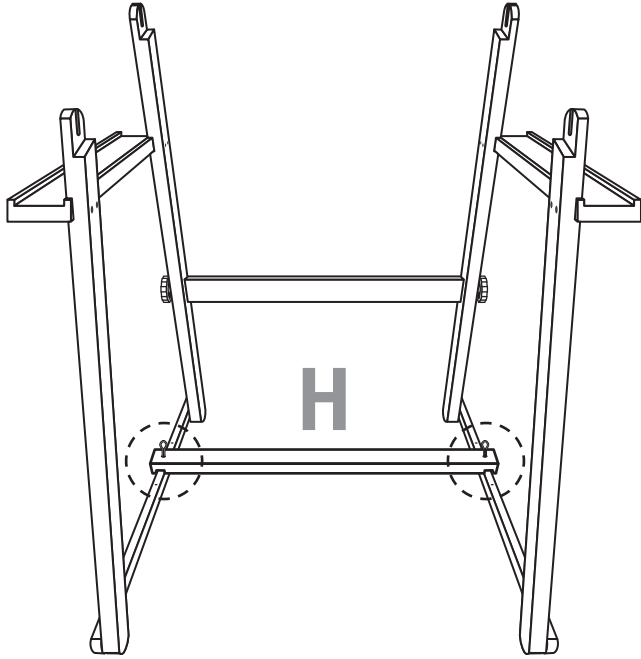
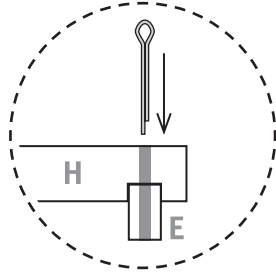

5

Bolts through the loom
sides.

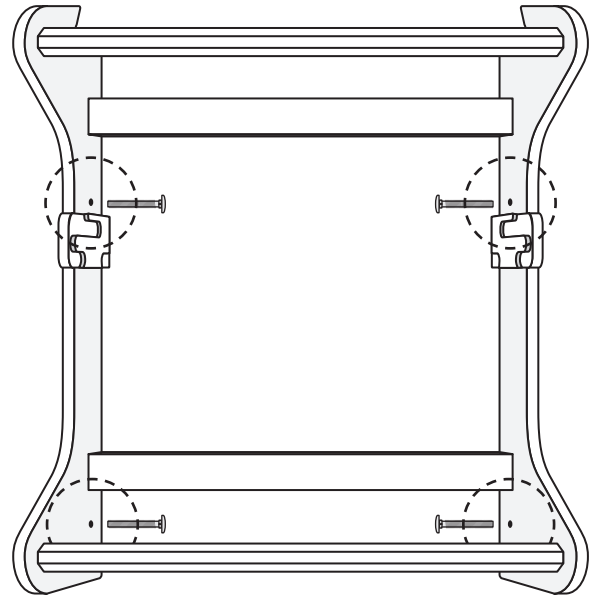
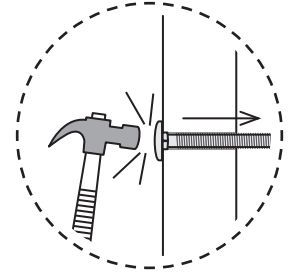

6

Lower the bolts into the front slots, then
the back slots and tighten the knobs.

