

## e-Ball Winder

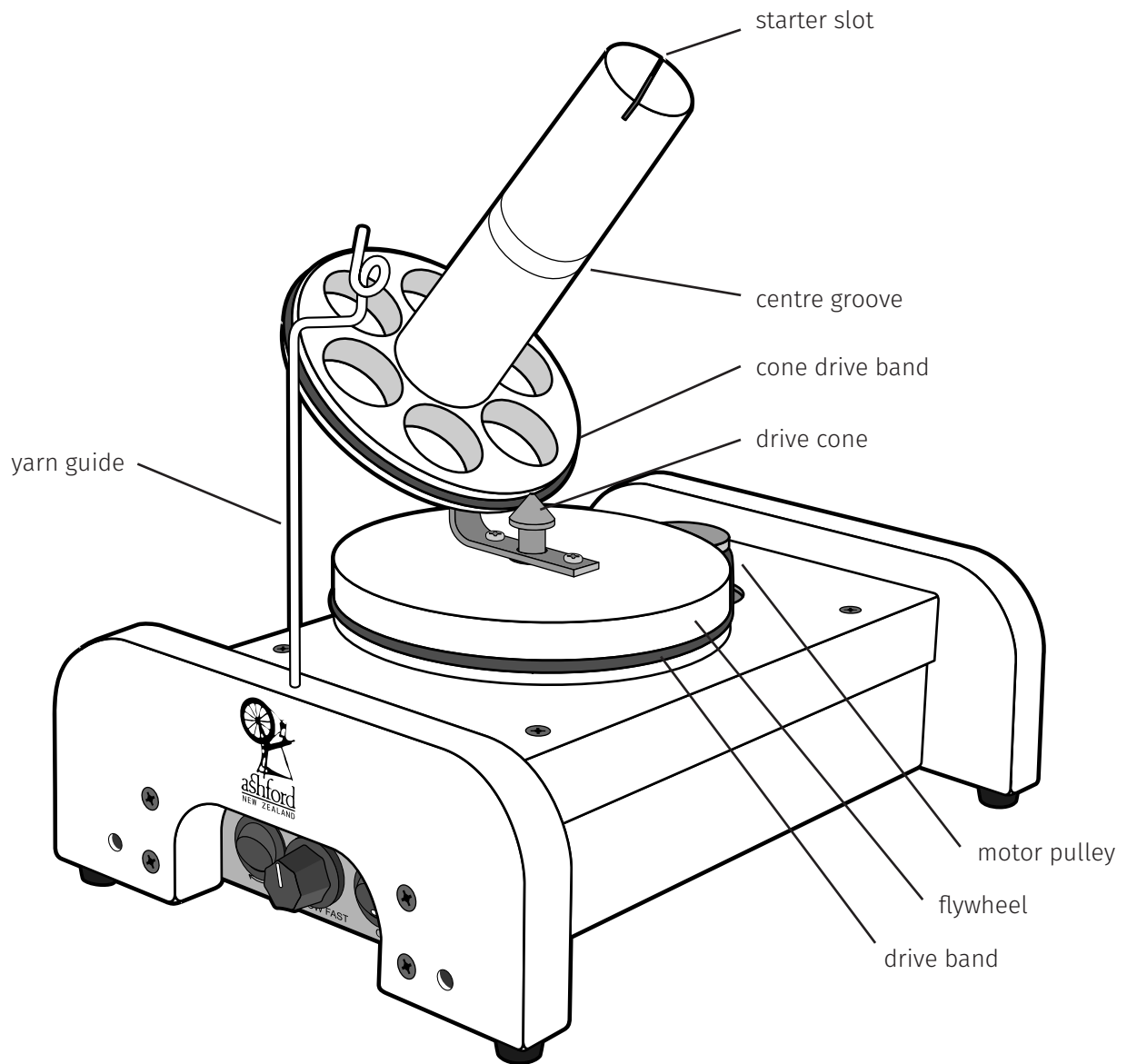

EBW280323V3

# ASSEMBLY INSTRUCTIONS FOR e-BALL WINDER

**Before commencing** - please read these instructions completely, identify the parts and note the safe operating procedures.

**Finish** - your e-Ball Winder has been lacquered prior to assembly. If desired Ashford Finishing Wax may be applied to further enhance its appearance.

## Controls

### Foot Switch

Plug the AC/DC adapter and foot switch into the respective holes under the e-Ball Winder.

We strongly recommend using the foot switch to start and stop the e-Ball Winder.

#### Recommended Foot Switch Mode

##### START

(while your foot is on the foot switch)



##### STOP

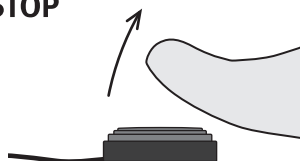

The e-Ball Winder will operate **ONLY** while your foot is on the foot switch. Lift your foot off and the e-Ball Winder will stop immediately. This enables you to stop and deal with tangles before they arrive at the yarn guide.

#### Alternate Foot Switch Mode

##### START



##### STOP



Press and hold the Foot Switch on and then turn the ON/OFF switch on. Lightly tap the foot switch to turn the e-Ball Winder ON and lightly tap again to turn it OFF. You can also operate your e-Ball Winder without the foot switch by turning it ON or OFF using the ON/OFF switch or speed control. However, our experience is that at full speed, the foot switch is a much more reliable way to stop tangles before they arrive at the yarn guide.

**NOTE:** Ensure the e-Ball Winder is switched OFF before removing the foot switch plug otherwise the motor will start.

**IMPORTANT:** Avoid tripping over or yanking on the foot switch or AC/DC adapter as this can damage or break the plugs and void your warranty. Please remove both cords when transporting your e-Ball Winder.

### Control Panel

#### FORWARD/REVERSE (Clockwise/Anticlockwise)

Forward is the normal way to wind balls. Reverse can be used to unwind your ball but slow the speed down first. Do not reverse the direction without first stopping the motor with the foot switch, ON/OFF switch, or speed control.

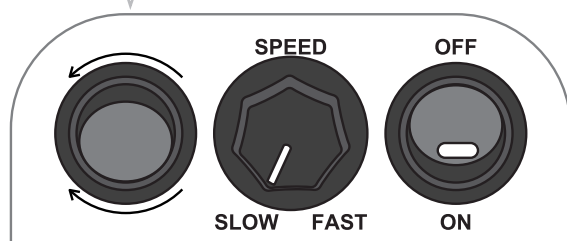

#### SPEED

Start on SLOW and turn the dial clockwise to gradually increase the speed until the desired RPM is reached. As the ball gets larger the yarn is drawn in faster and faster. Please reduce the speed once the ball is around 75% complete.

#### ON/OFF

The e-Ball Winder is fitted with a soft start which results in the motor taking 6 seconds to reach full speed. This enables you to make sure:

- 1) the ball is forming correctly.
- 2) the yarn is feeding off the skein evenly.
- 3) you are holding the yarn with the correct tension.

#### LED Light

The Red LED light indicates the status of your e-Ball Winder.

#### Constant On

The e-Ball Winder is operating normally.

#### Flashing short on/long off

The e-Ball Winder is on standby, the power is on, but the speed is set to ZERO.

#### Flashing short on/short off

The e-Ball Winder is ready to operate but the foot switch is OFF.

#### Flashing long on/short off

The AC/DC adapter is under load. Stop immediately:

- 1) check to make sure there is no yarn wrapped or tangled around the cone shaft or bearing.
- 2) reduce speed.
- 3) apply a drop of oil to the nylon bearing beneath the stainless-steel bracket located below the drive cone.

When you have finished winding balls of yarn and want to leave the e-Ball Winder, turn it OFF using the ON/OFF switch. Check the red LED light is off before you leave your e-Ball Winder.

## Winding – **Do not** leave the e-Ball Winder unattended when winding balls of yarn.

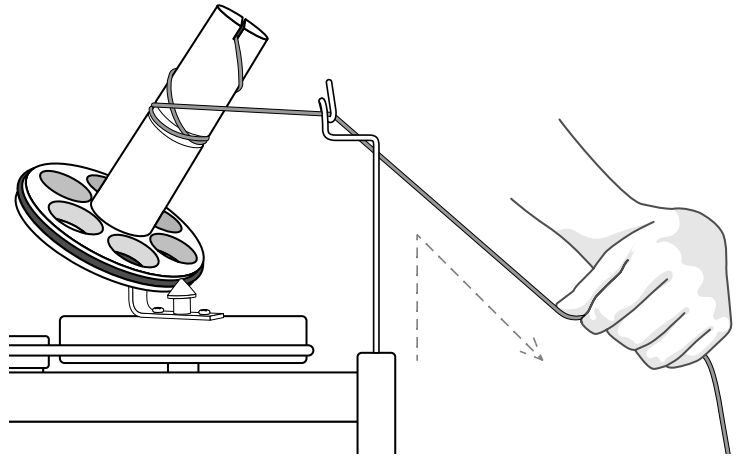
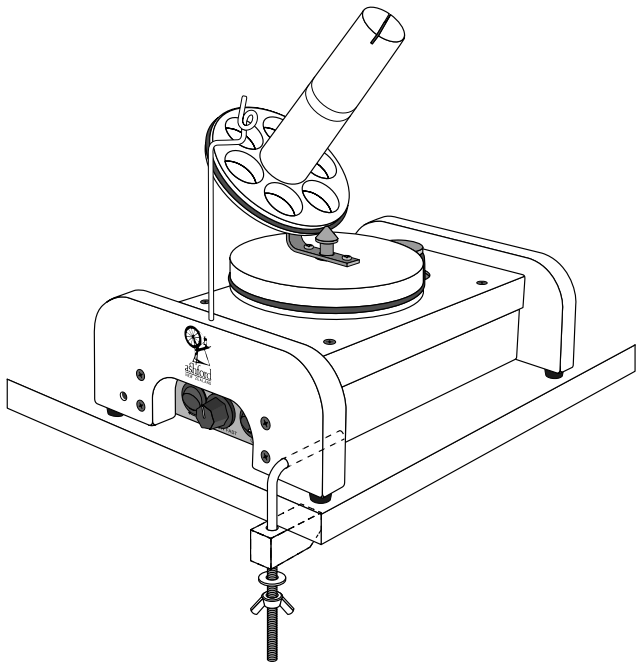

1. Locate the drive band onto the flywheel and motor pulleys.
2. Always clamp the e-Ball Winder to the table.
3. Feed the yarn through the pig tail of the yarn guide.
4. Place the end of your yarn into the starter slot at the top of the cone.
5. Check the Forward/Reverse switch is on forward (down) and the SPEED control is on SLOW. Switch the ON/OFF switch to ON. Press down on the foot switch to start the motor.
6. Hold the yarn at about a 45-degree angle down from the yarn guide. Encourage the yarn to start forming the ball on the centre groove of the cone.
7. It is very important to keep a constant tension on the yarn with your hand while feeding the yarn onto the same position of the yarn guide.

8. Adjust the SPEED control to achieve a comfortable speed.
9. As the ball increases in size twist the yarn guide 90° to avoid it touching the ball. This will occur on balls over 100gms (3½oz).

**IMPORTANT:** It is inevitable that the yarn will tangle or snag. Check the e-Ball Winder is securely clamped to the table. Always be ready to take your foot off the foot switch. Always control the yarn by keeping a constant tension on the yarn. Watch the yarn as it comes off the skeiner and be alert for snags or tangles. If in doubt SLOW DOWN.

### How to remove your ball of yarn

Turn the motor off using the foot switch or ON/OFF switch. Lift the end of the yarn out of the slot in the top of the cone. Use both hands, one either side of the ball of yarn and gently lift the ball off the cone while keeping the end of the yarn free.

### Maintenance / Lubrication

- We recommend a drop of Ashford Spinning Wheel Oil be regularly applied to the nylon bearing beneath the stainless-steel bracket located below the drive cone. **AVOID** getting any oil on the drive cone and the cone drive band.
- When not using your e-Ball Winder, reduce the tension on the drive band by taking it off the motor pulley.
- The ball bearings in the motors may be noisy for the first 5-10 minutes as they “run-in” and the grease is dissipated evenly.
- Replacement drive band sets available separately.

### Safe Operating Procedures

- Take care to ensure children and pets are always well clear of the e-Ball Winder while it is in use.
- Never leave the e-Ball Winder without switching it OFF at the ON/OFF switch.
- Always unplug the AC/DC adapter from the wall when not in use.
- Ensure the e-Ball Winder is switched off before removing the foot switch plug.
- Do not use your e-Ball Winder in damp or wet conditions.
- Never open the electronic compartment without first disconnecting it from the power supply.
- Do not leave the e-Ball Winder running unattended.

## Accessories - Available from your local Ashford Dealer.

---

### 12V cigarette cord

so you can wind balls away from home. Use this handy optional accessory to power your e-Ball Winder in your car, caravan, RV, boat or with a battery pack. Simply plug it into the cigarette lighter outlet.



## You might also like - Available from your local Ashford Dealer.

---

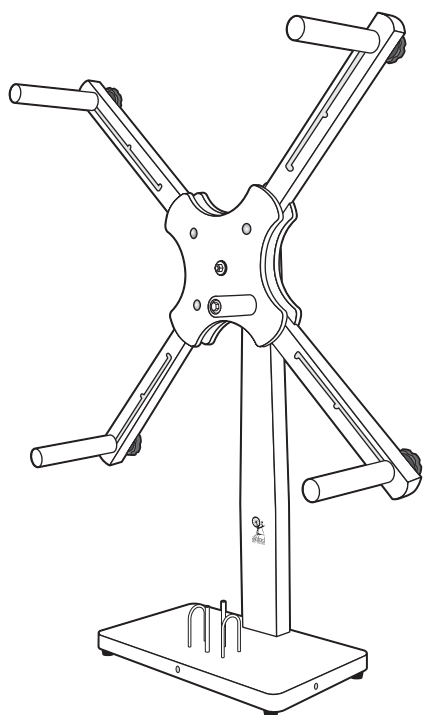

Skeiner 2

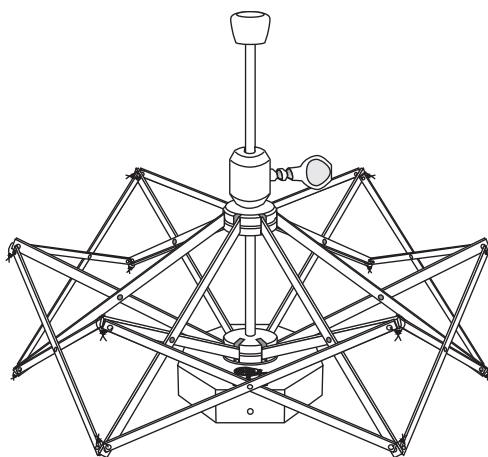

Wooden Umbrella Swift

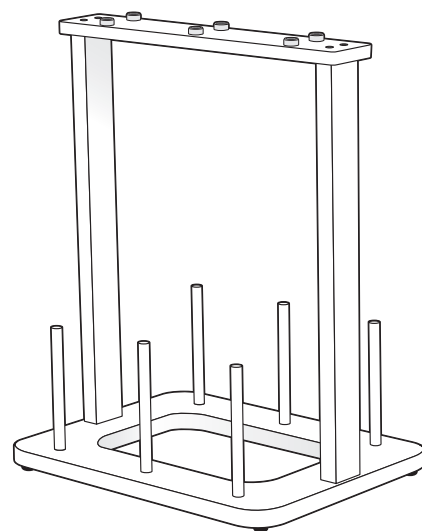

Yarn Stand

---

## More Information



### How-to videos on You Tube

Watch our how-to videos on You Tube.  
@AshfordNz



### Facebook

Join us on facebook.  
ashford.wheels.ooms

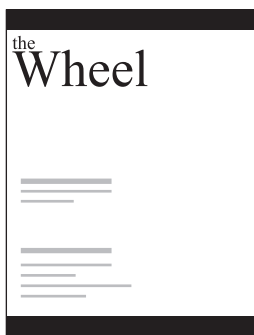

### The Wheel Magazine

Ashford's annual fibrecraft magazine. Spinning, weaving, felting, dyeing and knitting projects, patterns and articles from around the world. To receive the premium version delivered to you, subscribe at: [www.ashford.co.nz/subscribe](http://www.ashford.co.nz/subscribe)