

ELIZABETH 30 SPINNING WHEEL

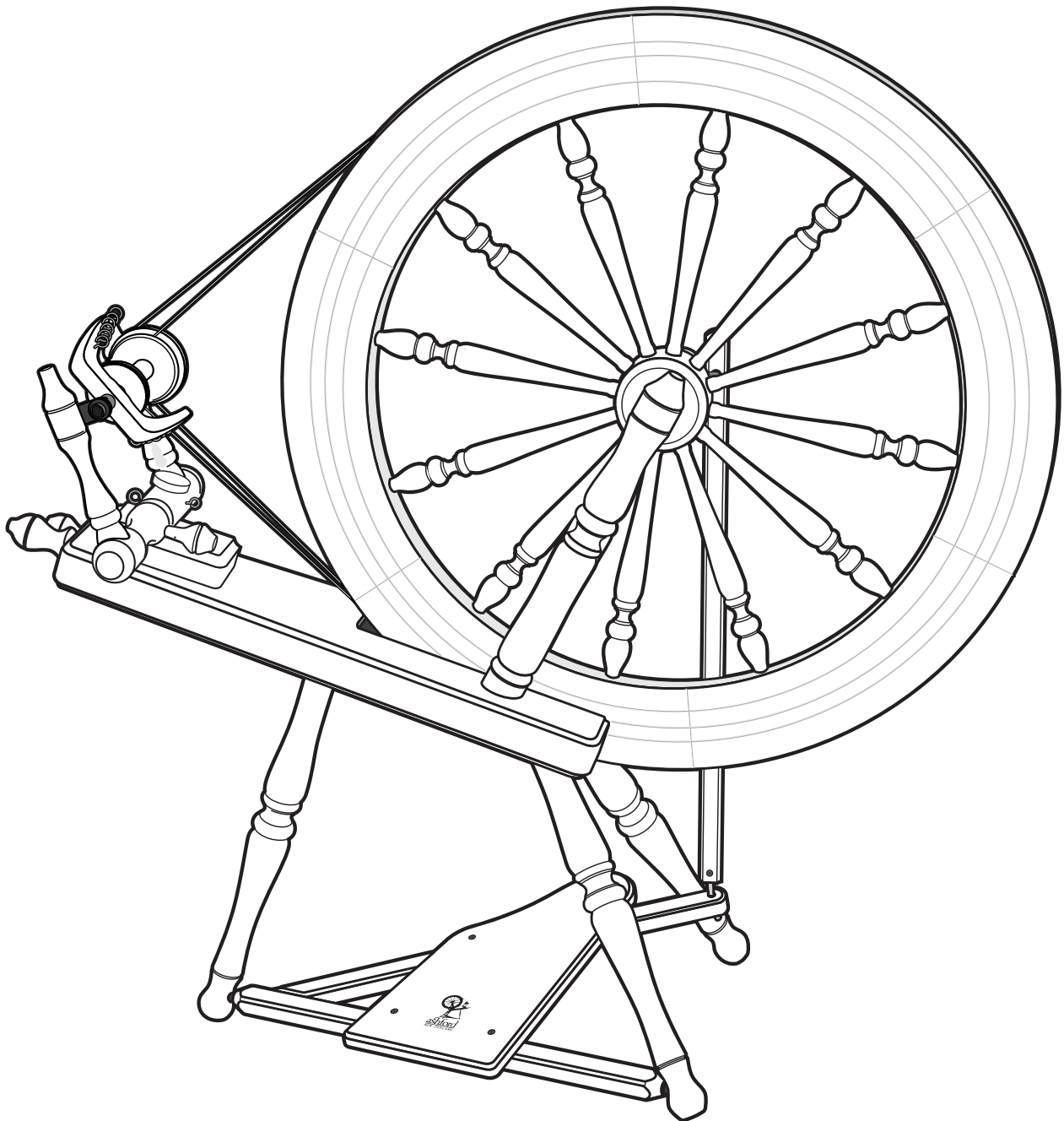

ESW211122V5

TOOLS REQUIRED

⊕Screwdriver, Hammer and Candlewax (for wood screws and dowel ends).

BEFORE COMMENCING:

Read the instructions completely, identify the parts and note the assembly sequence.

FINISH THE WOOD:

We recommend that the wood surfaces be sealed before assembly. This spinning wheel has been finished with a water based lacquer to protect the kiln dried wood from climatic changes and enhances the beauty of the wood.

FOR THE ULTIMATE FINISH:

To enhance or restore the finish use our natural Ashford Wax Polish. Just rub it on with the applicator pad and wipe it off with a soft cloth.



Drive Belt



Nylon Brake Band



Spanner

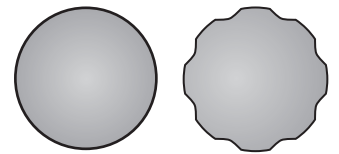

Knobs



12mm (1/2") Pan Head Screws



19mm (3/4") Pan Head Screws

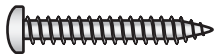

25mm (1") Pan Head Screws



25mm (1") Countersunk Screws



32mm (1 1/4") Countersunk Screws



38mm (1 1/2") Countersunk Screw

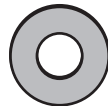

12mm (1/2") Washers

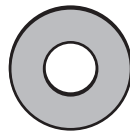

16mm (5/8") Washer

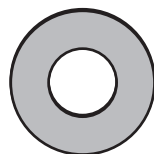

19mm (3/4") Washers



Inner Shell



45mm (1 3/4") Tension Pin



62mm (2 1/2") Hub Pin

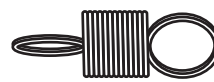

Tension Springs



Flyer Hooks



Small Barrel Nut



Screw Eye



Large Barrel Nut



Rubber Feet



100mm (4") Bolts

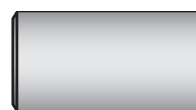

Large Crank Spacer



Short Crank Spacer

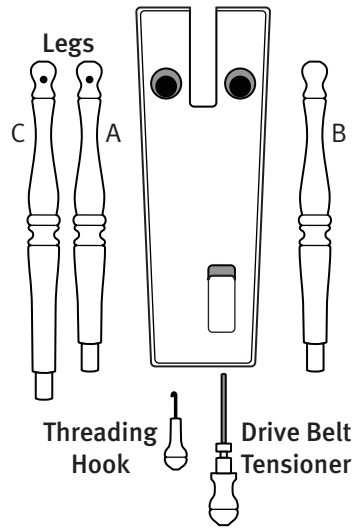
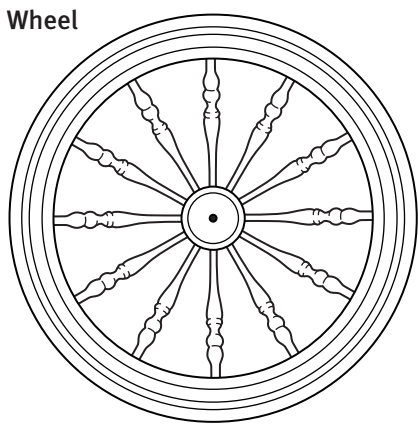

Maid Upright
1/2" (12mm)
Hole

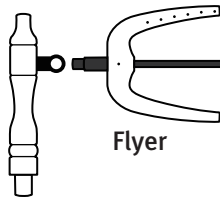

Flyer

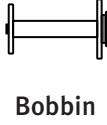

Bobbin



Whorl

Maid Upright
1/4" (6mm) Slot

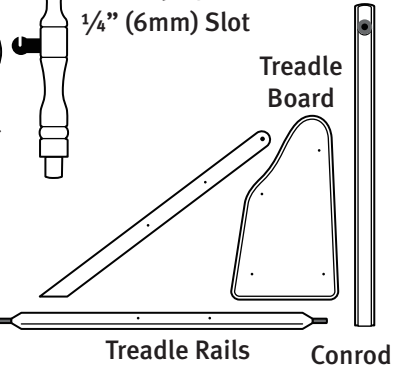

Treadle Board

Treadle Rails

Conrod

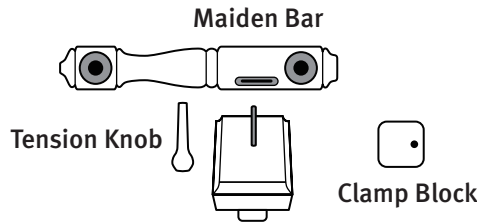

Maiden Bar

Tension Knob

Clamp Block

Maiden Bar Base

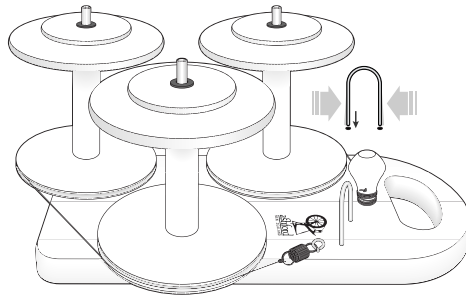

Competition Lazy Kate

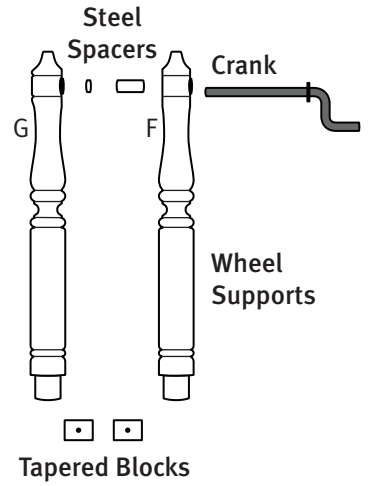

Steel Spacers

Crank

G

F

Wheel Supports

Tapered Blocks

STEP 1 - Single treadle

Join the two treadle rails with a 38mm (1½") countersunk screw. Secure the treadle board to the treadle rails with four 25mm (1") countersunk screws.

STEP 2

Lie the table face down on a flat clean surface. Place a towel under the table to protect it from damage. Wax the dowel ends of the legs so they can be twisted. Note the position of the holes for the treadle pins.

Insert the short leg A with the hole for a treadle pin into the hole in the table as illustrated. Partially insert long leg C also with a hole for a treadle pin into the table. Insert the pins in the end of the treadle rail into the holes in the short leg A and long leg C. Twist the legs until the treadle assembly Single or Double Treadle, moves freely. Then tap both legs fully into the base.

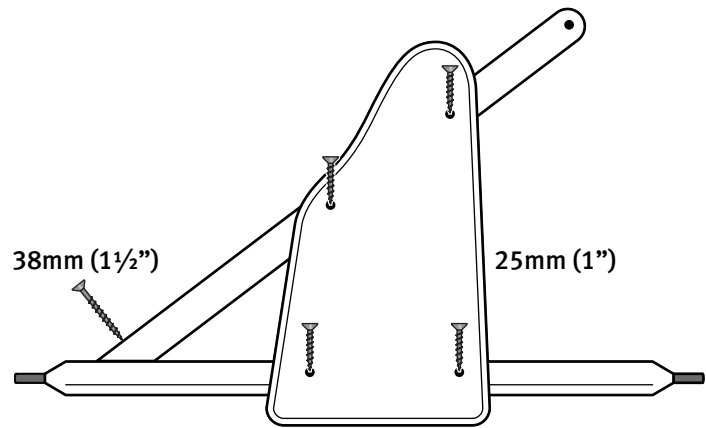

38mm (1½")

25mm (1")

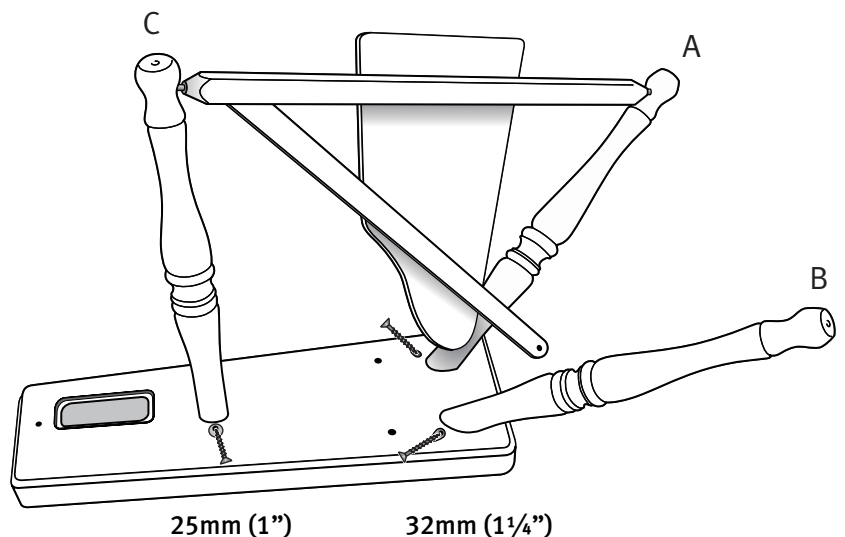

25mm (1")

32mm (1¼")

STEP 3

Insert the other short leg B into the table and tap all legs home. Secure the short legs with 32mm (1¼") screws and the long leg with a 25mm (1") screw.

STEP 4

Sit the table on its legs. Insert the wheel support G into the hole in the table on the side closest to the spinner. Note the ball bearing is to the inside. It may be more convenient to do the next stage on a table. Position a large barrel nut into the hole in wheel support G. Note the slot in the nut is in line with the hole.

Place a 19mm (¾") washer onto a 100mm (4") bolt and insert the bolt through the tapered blocks, table, support G and into the barrel nut as illustrated. Repeat with wheel support F. Note the bearing faces out.

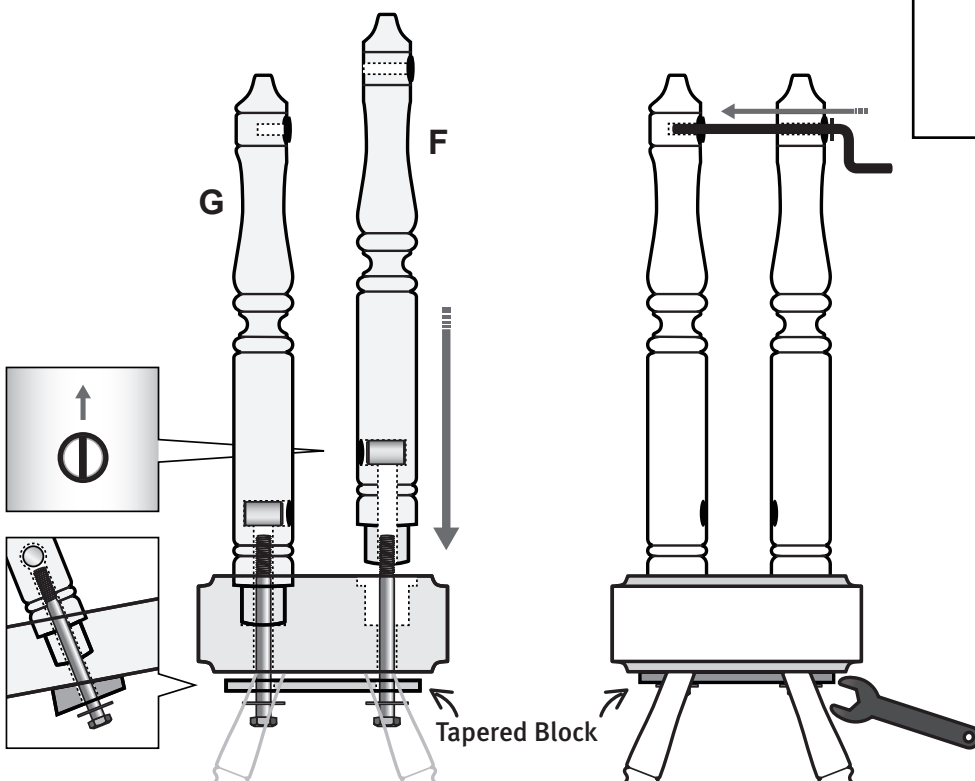
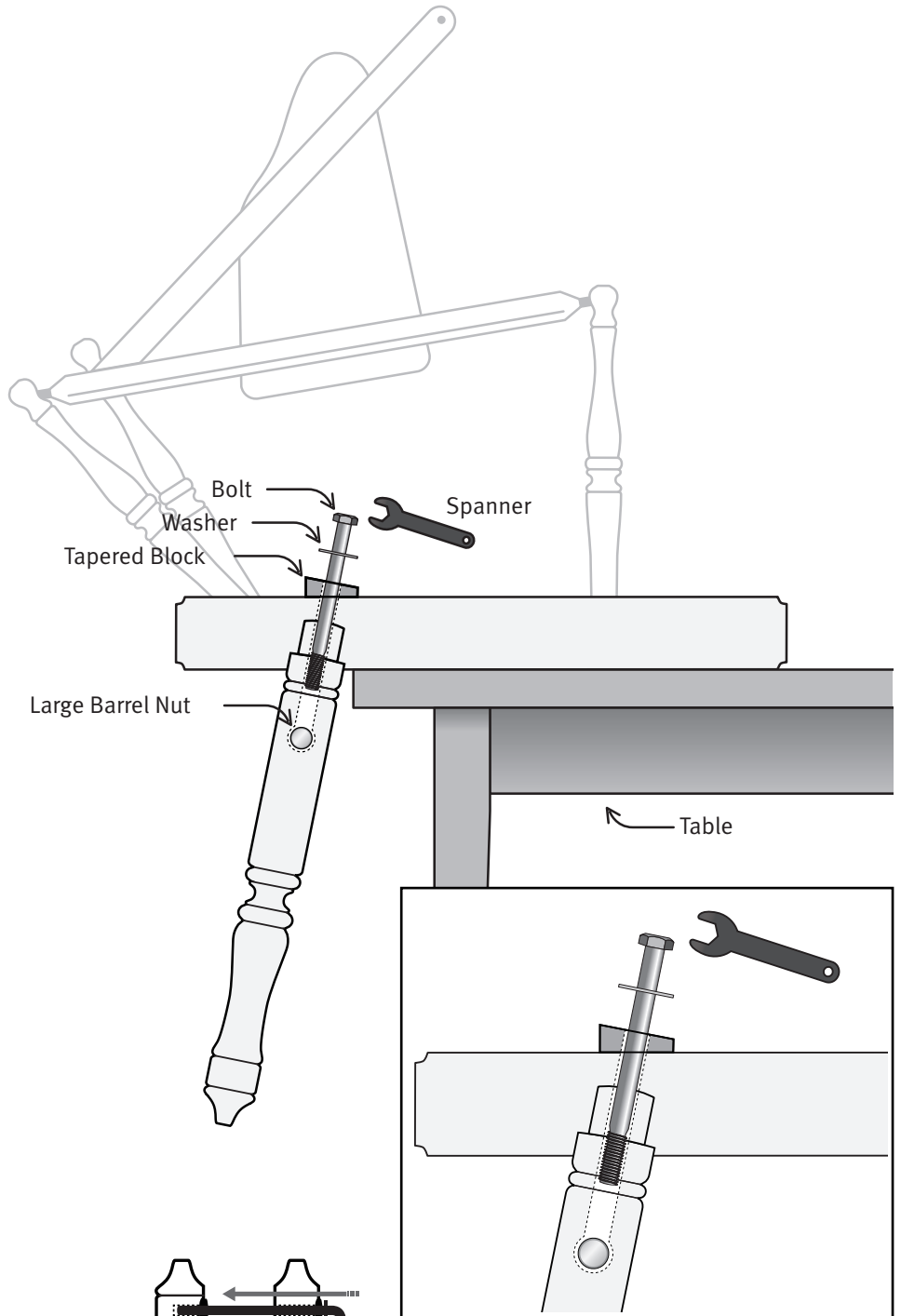

STEP 5

Push the crank through both ball bearings and check it turns freely. If not twist the wheel supports until it does. Then firmly tighten the bolts with the spanner provided.

STEP 6

Insert the crank through the bearing in wheel support F. Slide the long crank spacer onto the crank as shown. Rub a little candle wax onto the crank. Then place the wheel into position with the groove for the hub pin away from the spinner and push the crank through the hub. Turning the wheel as you push will make this easier. Stop when the crank protrudes about 3mm ($\frac{1}{8}$ "") through the hub.

Then slide the short crank spacer onto the crank. It is easier if you hold the spacer with a pair of fine pliers or scissors. Then push the crank through the hub and into the ball bearing until the hole for the hub pin aligns with the slot in the hub.

STEP 7

Once the hole in the crank aligns with the slot in the hub, carefully tap the 62mm ($2\frac{1}{2}$ "") hub pin through the hub and hole in the crank.

STEP 8

Insert the conrod joint into the large slot in the treadle rail.

Note the crank bearing faces the back of the spinning wheel. Hold the conrod joint with one hand on either side of the treadle rail. With both hands, turn the conrod joint a $\frac{1}{4}$ turn, stretch and slide it into the small slot and turn it back a $\frac{1}{4}$ turn until it clicks into place.

STEP 9

Slide the inner bearing shell of the conrod universal joint onto the crank until it clicks into the groove. Then snap the conrod onto the universal joint on the crank.

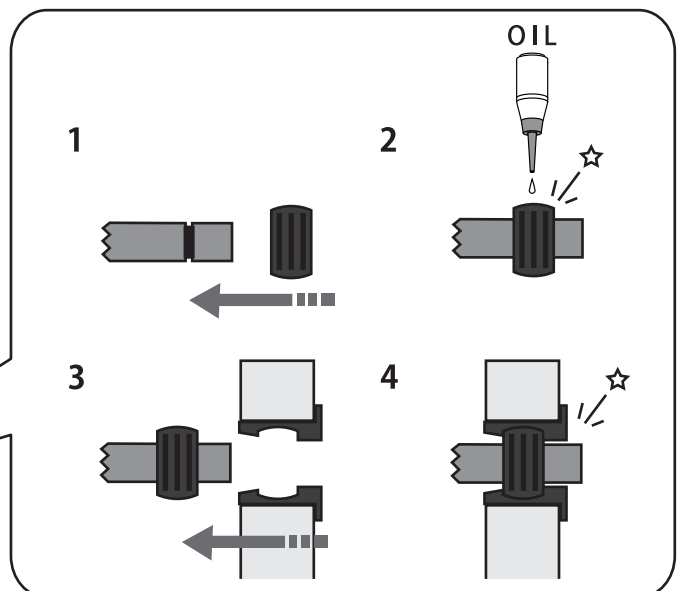
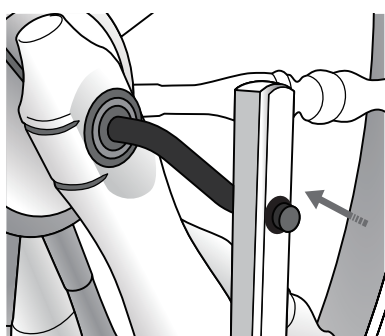
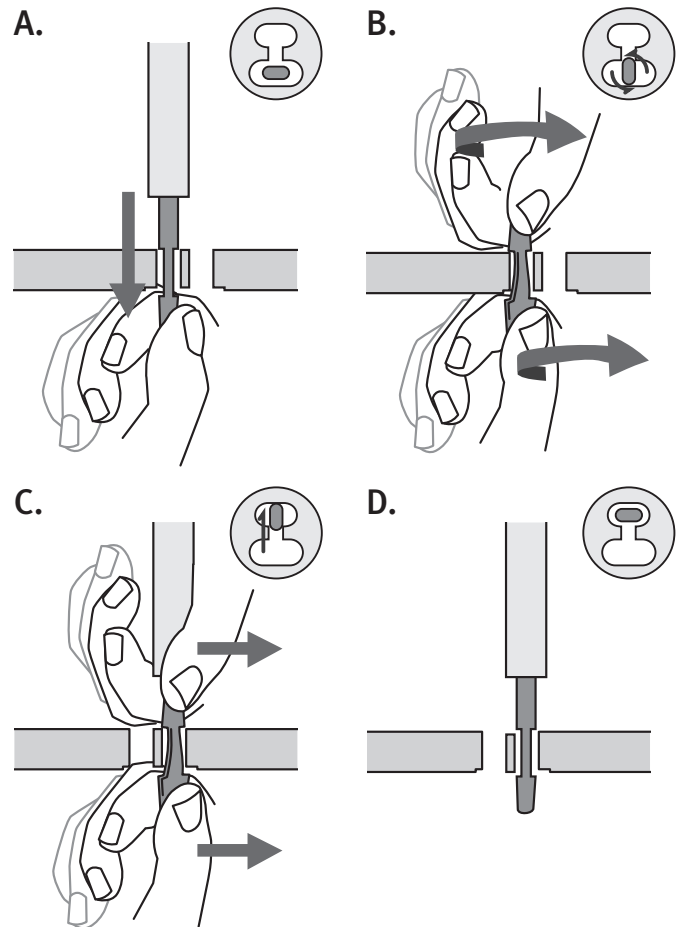
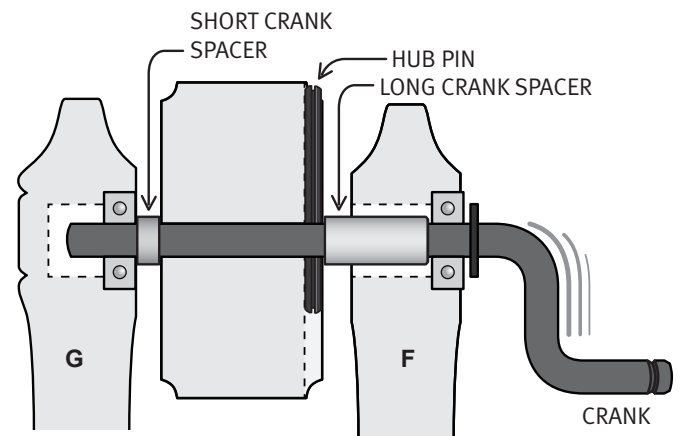

STEP 10

Sit the spinning wheel onto its front legs and wheel. Wax the sides of the maiden bar base and place it into the slot in the table. Slide the small barrel nut into the hole in the lower block, then thread the drive belt tensioner into the barrel nut.

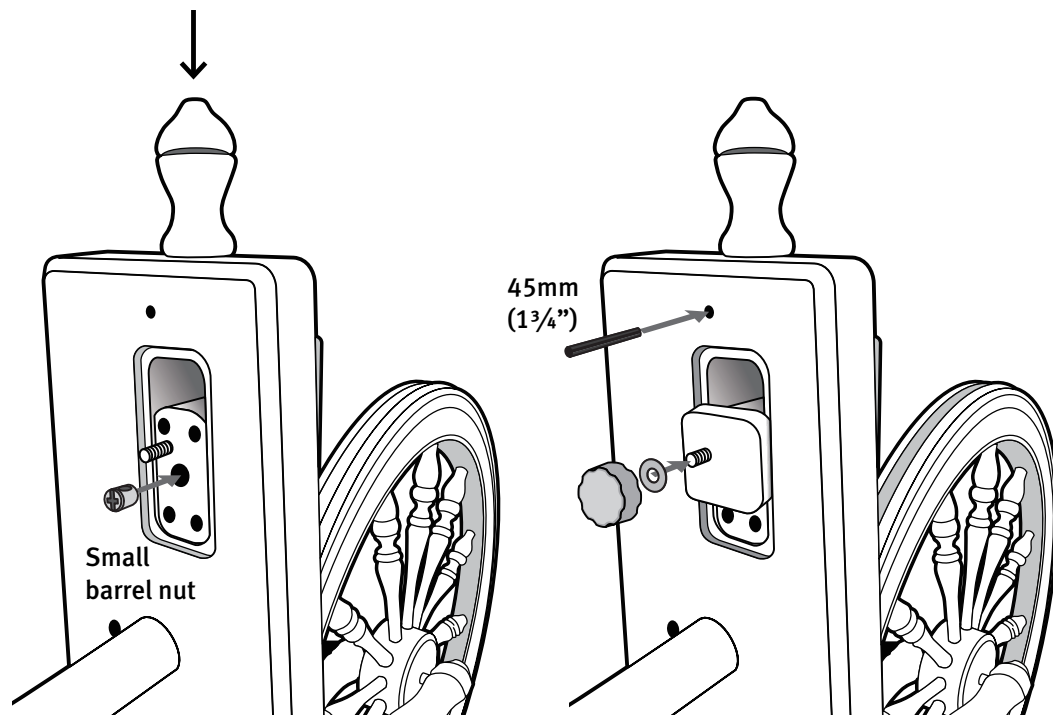

STEP 11

Place the wooden clamp block onto the bolt in the base of the maiden bar and secure with a 16mm ($\frac{5}{8}$ ") washer and knob. Before adjusting the drive belt tension, loosen the knob. Retighten to hold the maiden bar firm.

STEP 12

Wax the 45mm ($1\frac{3}{4}$ ") tension pin and softly tap it into the hole in the underside of the table to lock the drive belt tensioner in position. Important - leave 12mm ($\frac{1}{2}$ ") protruding so it can be removed if necessary.

STEP 13

Wax the dowel ends of the two maid uprights and push into the holes in the maiden bar. Note the maid upright with the 12mm ($\frac{1}{2}$ ") hole is closest to the spinner and the maid upright with the 6mm ($\frac{1}{4}$ ") slot is on the opposite side. Check the bearings are at 90 degrees to the maiden bar and secure with 25mm (1") pan head screws and small washer. Do not over tighten as you may need to twist them later.

STEP 14

Thread a flyer hook into the pilot hole in the back and screw eye into the pilot hole in the front of the maiden bar.

STEP 15

Position the maiden bar onto the maiden bar base and secure with a 16mm ($\frac{5}{8}$ ") washer and wooden knob.

STEP 16

Thread the flyer hooks into the pilot holes in the flyer.

STEP 17

Apply a drop of oil to the flyer spindle and slide a bobbin on. Note the flat surface on the end of the spindle. Place the middle size flyer whorl onto the end of the spindle and rotate it until it pushes on easily. A drop of Vaseline on this joint will make it easier to change bobbins.

STEP 18

Place the flyer and bobbin into the bearings in the maid uprights. Loosen the clamp block and unwind the belt tensioner to the end of its travel so the maiden bar is closest to the wheel.

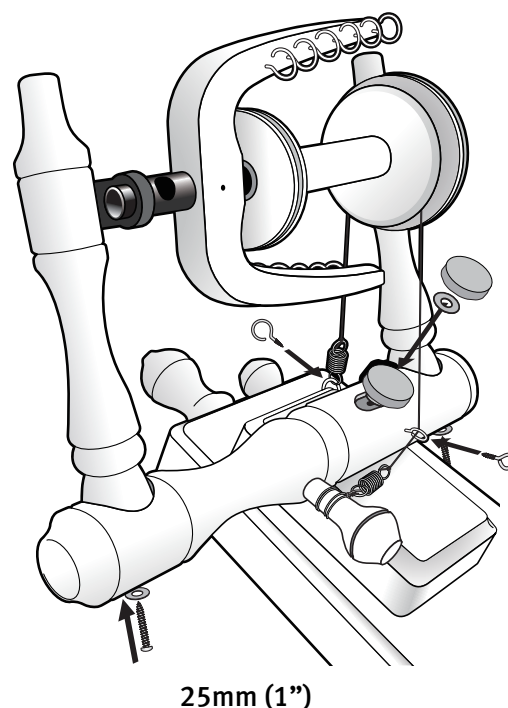

STEP 19

Now choose to either set your wheel for Double Drive or Single Drive.

A. Double Drive:

Place the drive band over the wheel and wrap it in one continuous band around the small bobbin whorl, over the wheel again, around the large flyer whorl and tie the 2 ends with a flat knot. Tighten the belt tensioner until both flyer and bobbin rotate and then tighten the clamp block. Check the alignment of the drive belt with the wheel and flyer and bobbin whorls. If necessary loosen the top knob, move the maiden bar horizontally until aligned and then retighten.

Your Elizabeth 30" has 2 whorls to allow a variety of yarns to be spun.

Standard - 10.5, 13.5 and 18.5:1.

High Speed – 14.0, 18.5 and 28:1. On 28:1 please use the wheel as a single drive.

Because the Elizabeth 30" has such a large wheel, when first using the wheel, please treadle very slowly to avoid over twisting your yarn.

B. Single Drive / Scotch Tension:

Place both ends of the drive belt onto the large flyer whorl. Push the tension knob into the tapered hole in the maiden bar. Tie a spring to one end of the nylon brake band and hook it over the cup hook. Position the brake band over the bobbin whorl, through the screw eye and cut it where it touches the tension knob. Tie both ends of the nylon brake band to the second spring half way between the screw eye and tension knob, thread the brake band through the hole in the tension knob and tie a knot. Trim off any surplus. When spinning with double drive remove the brake band and wrap it around the tension knob.

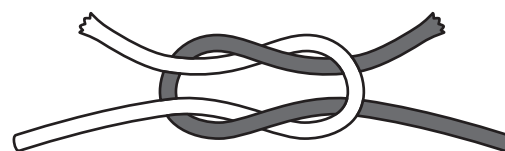

Flat Knot

STEP 20

Place the threading hook into the hole in the end of the table.

STEP 21

Assemble the Competition Lazy Kate.

- Attach the 4 rubber feet with 12mm (1/2") screws.
- Insert the 3 steel rods into the holes in the base.
- Squeeze the steel yarn guide and insert it into the 2 holes.
- Tie one end of the nylon brake band to the tension spring.
- Thread the screw eye with the tension spring attached into the pilot hole in the base.
- Thread the other end through the hole in the tension knob and tie a knot. Then insert the tension knob into the hole in the base.

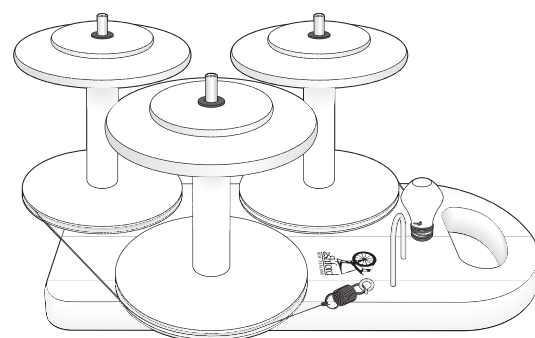

Competition Lazy Kate

STEP 22

Your Ashford Elizabeth 30 Spinning Wheel is now ready to use. Refer to the "Learn to Spin Booklet" for detailed spinning instructions. For silent efficient spinning, regularly lubricate the flyer, bobbin, conrod and treadle bearings with Ashford Spinning Wheel Oil. The wheel is supported on sealed for life ball bearings and do not need oiling.

Happy Spinning!

