

## RIGID HEDDLE TABLE STAND

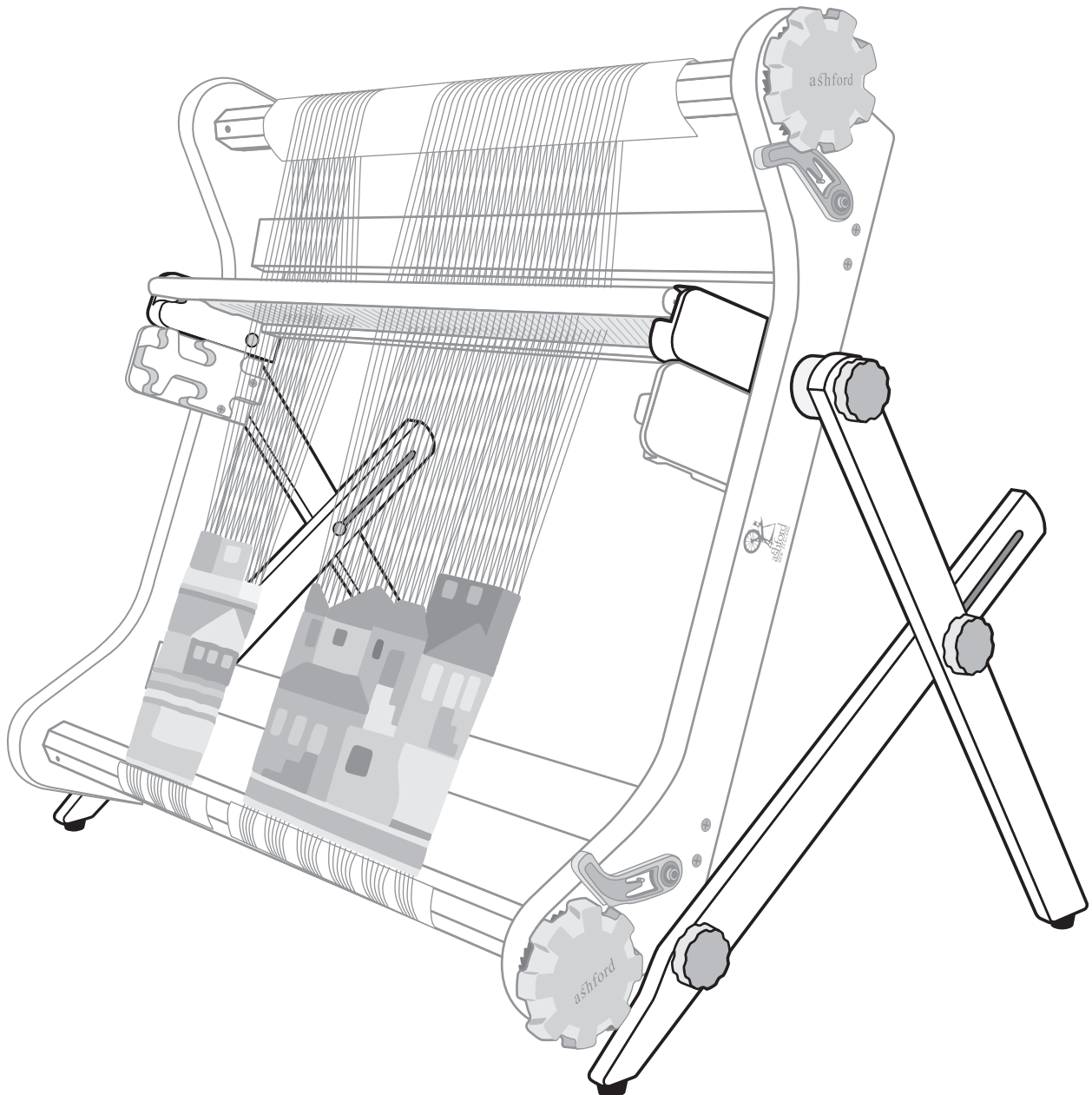

RHTS210324

# ASSEMBLY INSTRUCTIONS FOR THE ASHFORD RIGID HEDDLE TABLE STAND

**Before commencing:** Please read these instructions completely, identify the parts and note the assembly sequence. Use the sandpaper supplied to remove any sharp edges and corners. To make assembly easier use candle wax on the screws.

**Finishing:** We recommend that the wood surfaces be waxed or sealed before assembly. This protects the kiln dried wood from climatic changes and prevents it getting dirty or stained. The timber has a lovely variety of colour and grain. For a silky smooth matt finish, use the Ashford Finishing Wax Polish to enhance the natural colours and character of this timber.

**For older models:** If your Rigid Heddle Loom does not have holes in the sides, mark the holes as shown and drill them with a 6mm (1/4") bit.

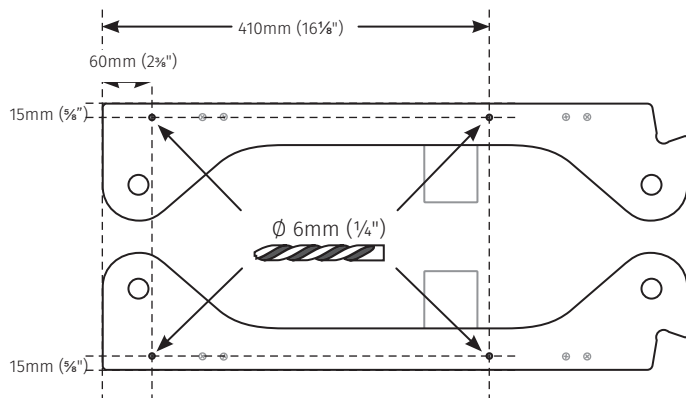

## Tools Required



## Important

Please warp your loom as usual before you attach the stand. Leave the reed in the rest position.

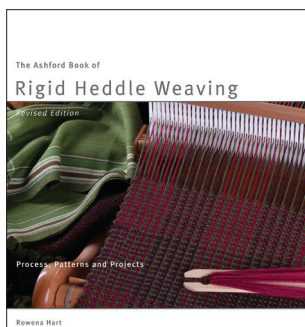
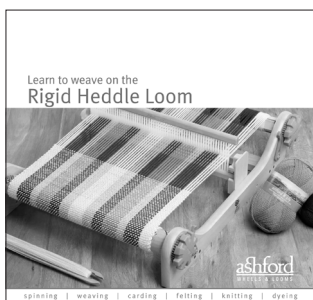

## Real Scale Hardware List

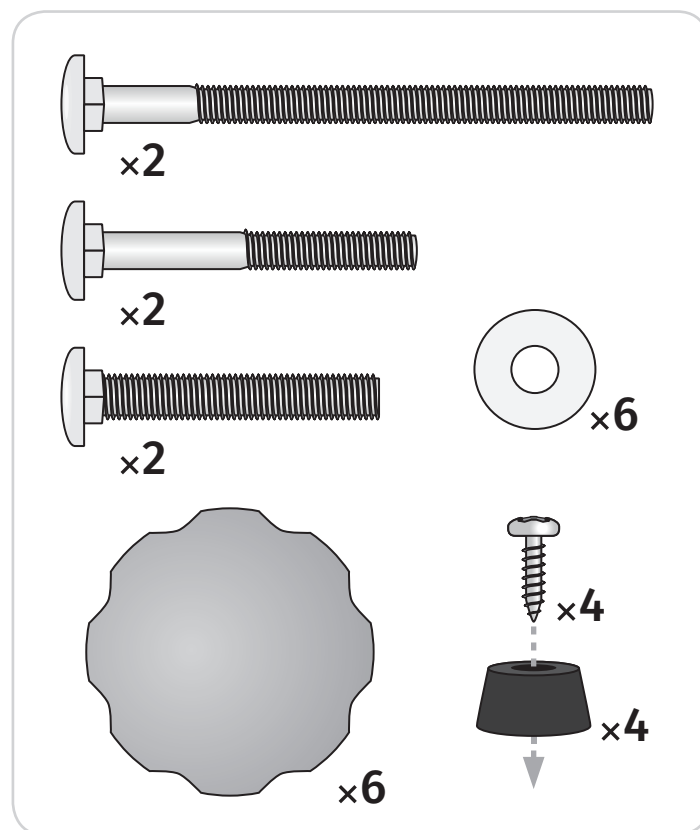

## More Information



**How-to videos on You Tube**  
Watch our how-to videos on You Tube.  
@AshfordNZ



**Blog**  
For inspirational articles, patterns and projects. Subscribe for free to the Ashford Blog [www.ashford.co.nz/blog](http://www.ashford.co.nz/blog)



**Facebook**  
Join us on facebook [ashford.wheels.ooms](https://www.facebook.com/ashford.wheels.ooms)



Attach the 4 rubber feet to the legs with 12mm (1/2") screws

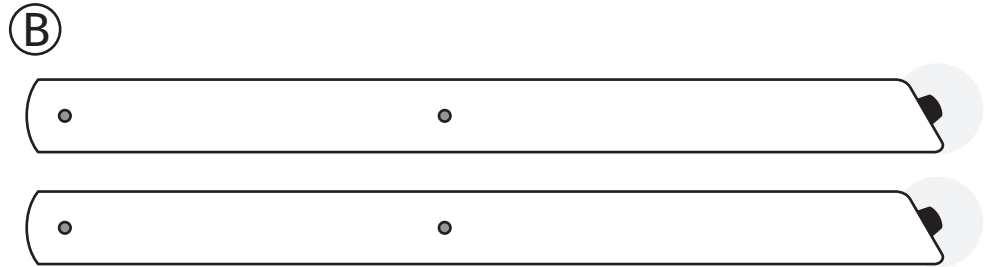
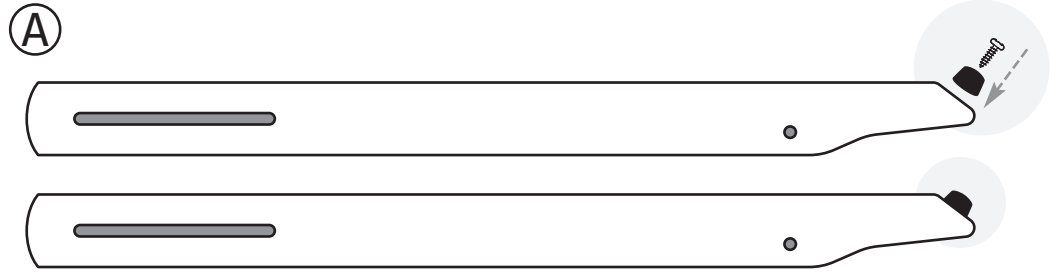
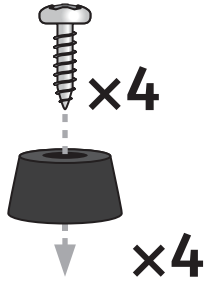

Secure the shaped legs A to the front holes in the loom side with 45mm (1 3/4") bolts, washers and knobs.

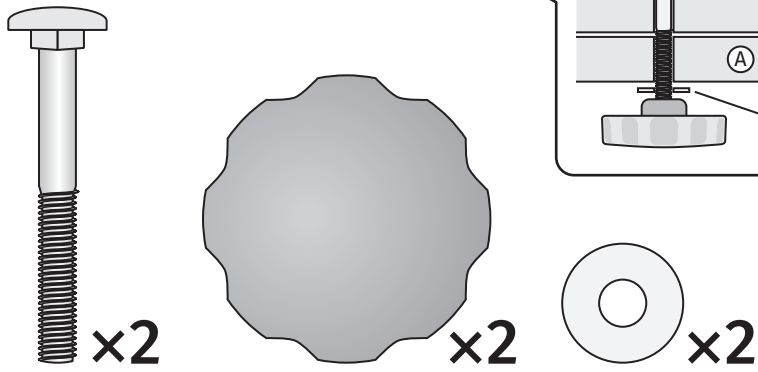
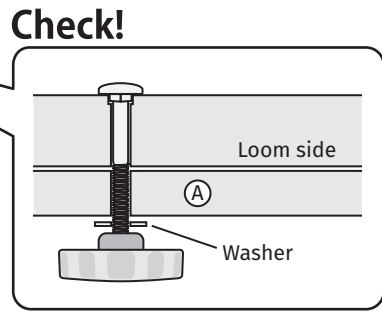
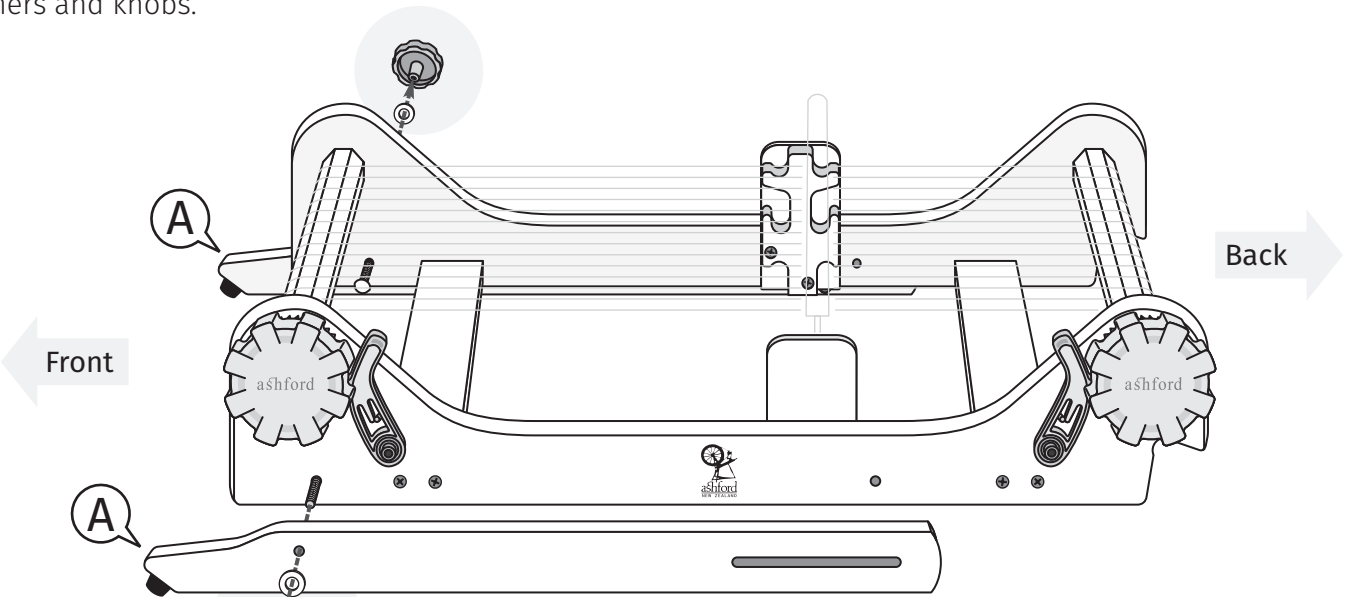

3



x2

Push the 75mm (3") bolt through the reed support block and side as illustrated followed by the spacer.

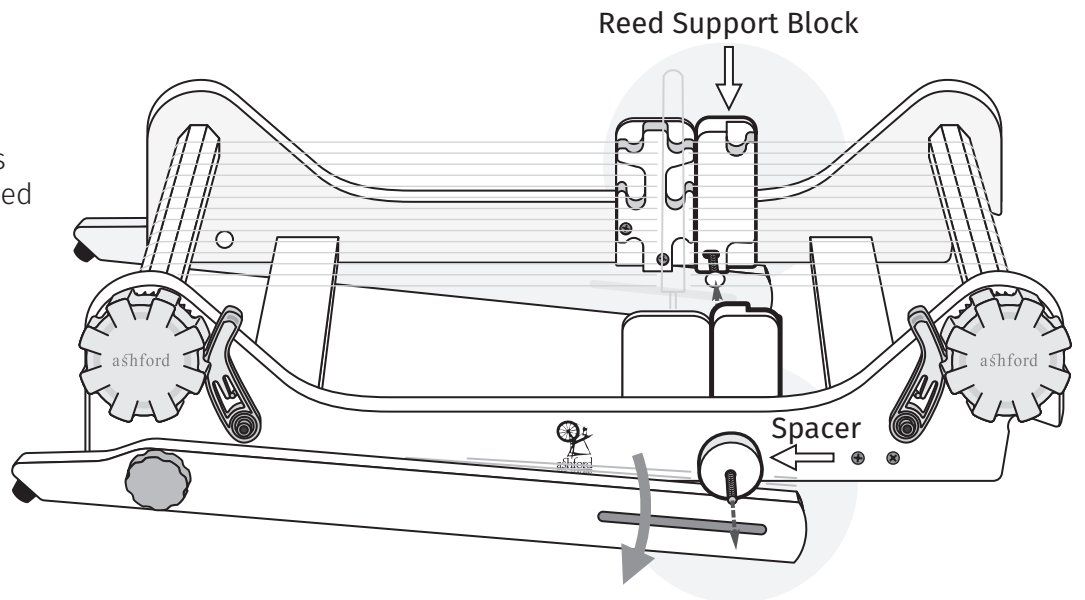

4

Then locate a leg B as illustrated and secure with a washer and knob. Repeat for the other side.

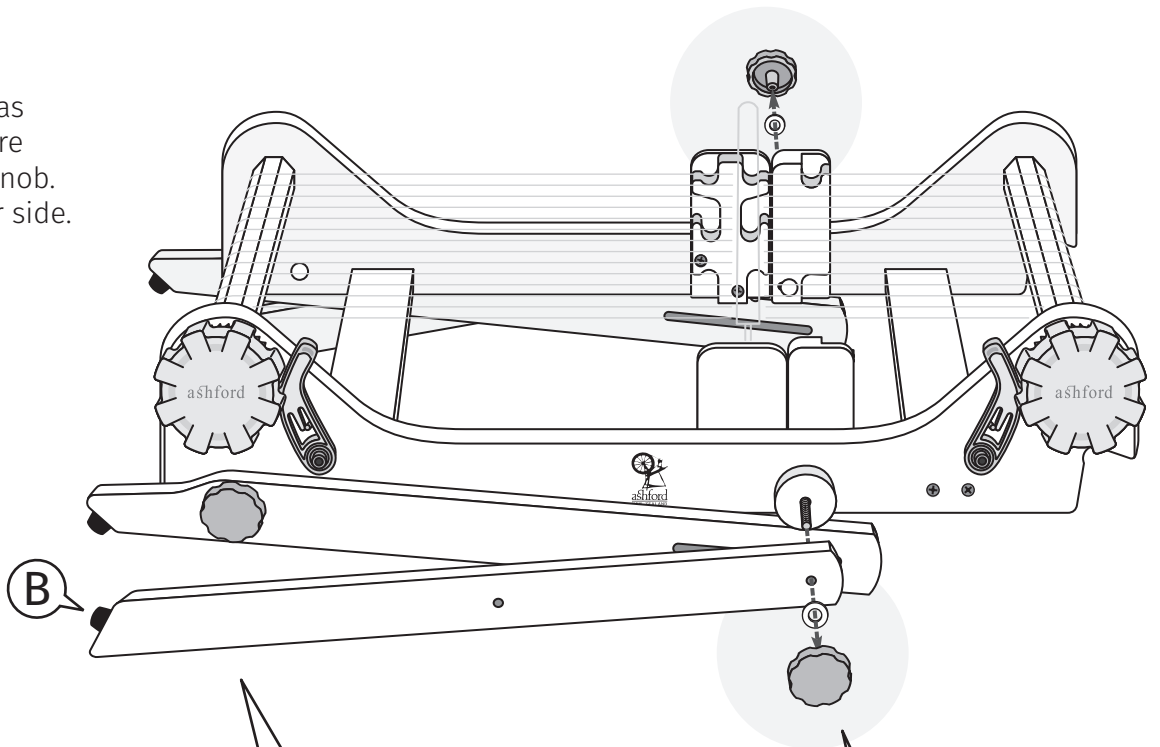

Check!

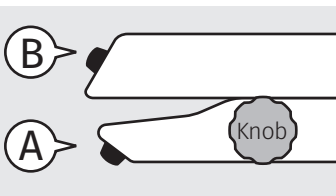
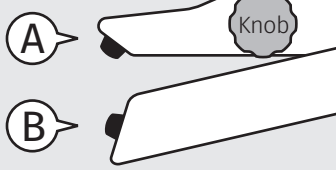

Check!

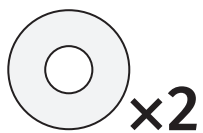
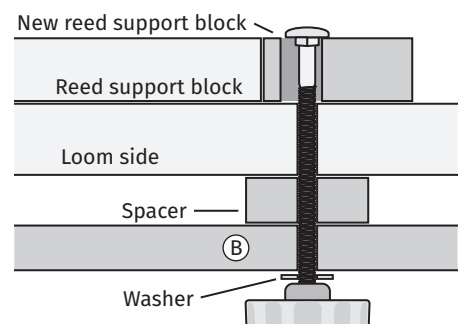

x2

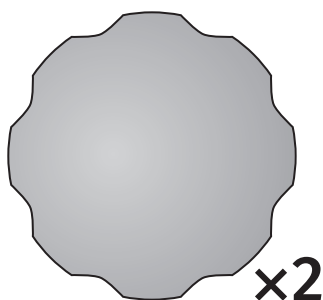

x2

**5**

Push a 40mm (1½") bolt through the slot in leg A, through the hole in leg B and secure with a washer and knob. Repeat for the other side.



x2



x2

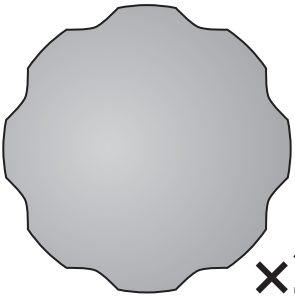

x2

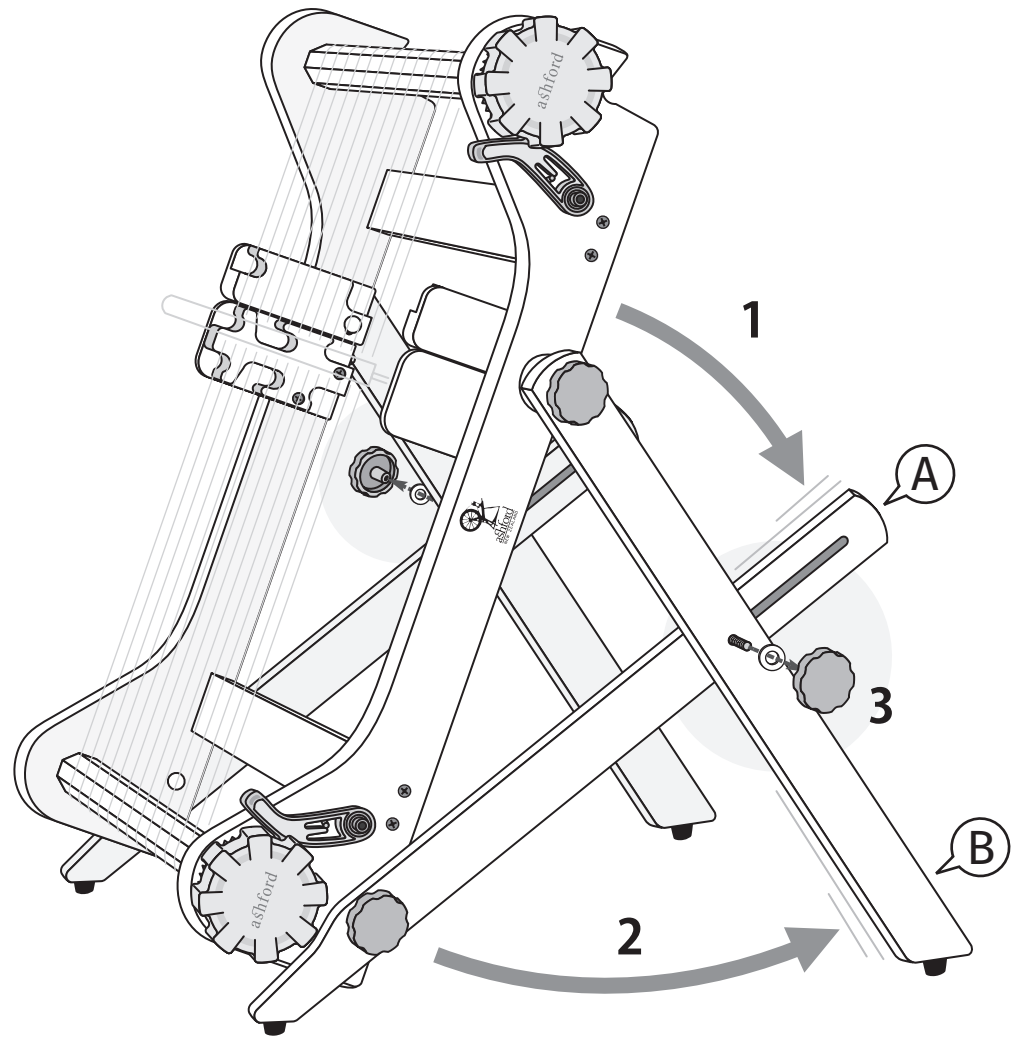

**6**

Push the new reed support block firmly against the original reed support block and tighten both knobs.

**Check!**

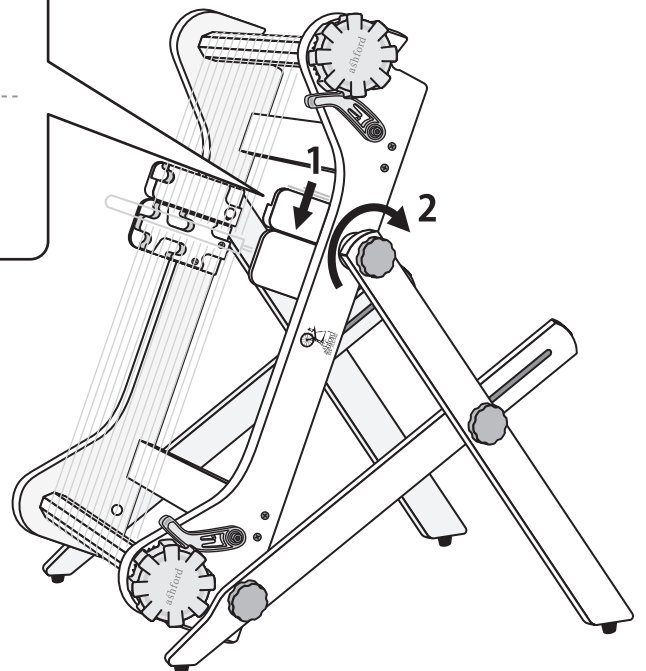
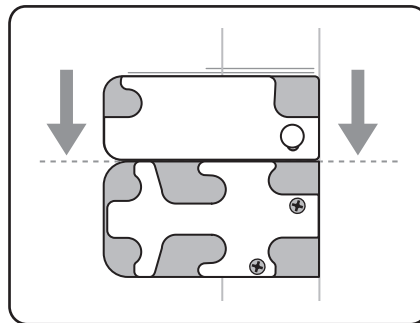

## Adjusting the angle

Adjust the angle of the loom by loosening the back knobs, slide the bolts along the slots, then retighten. Check that both legs are in the same position to ensure all 4 legs touch the table.

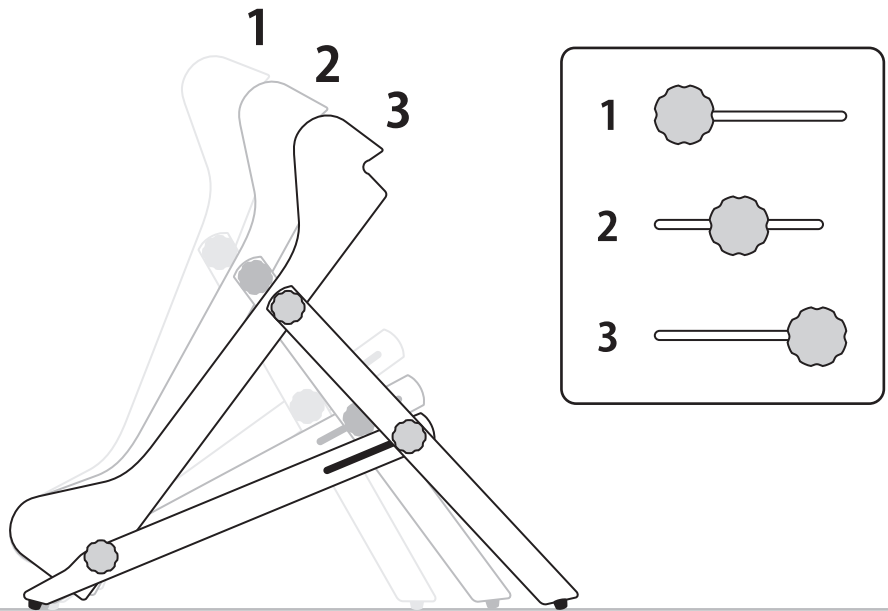

## Changing the shed

To change from the down position to the up position, first lift the back reed rail up, slide forward and place into the up position.

To change from the up position to the down position, pull reed slightly forward, tip the front of the reed down, slide reed back, feed the top reed rail into the top position and lower the back reed rail into the back position.

### Reed positions

Rest (neutral) position - use the rest position of the original reed support.

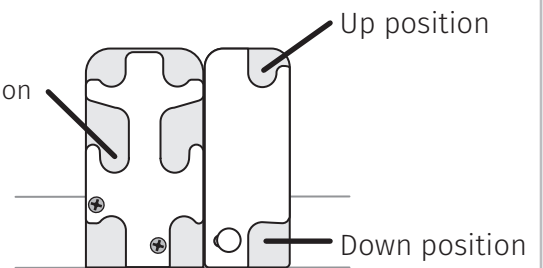

### DOWN → UP

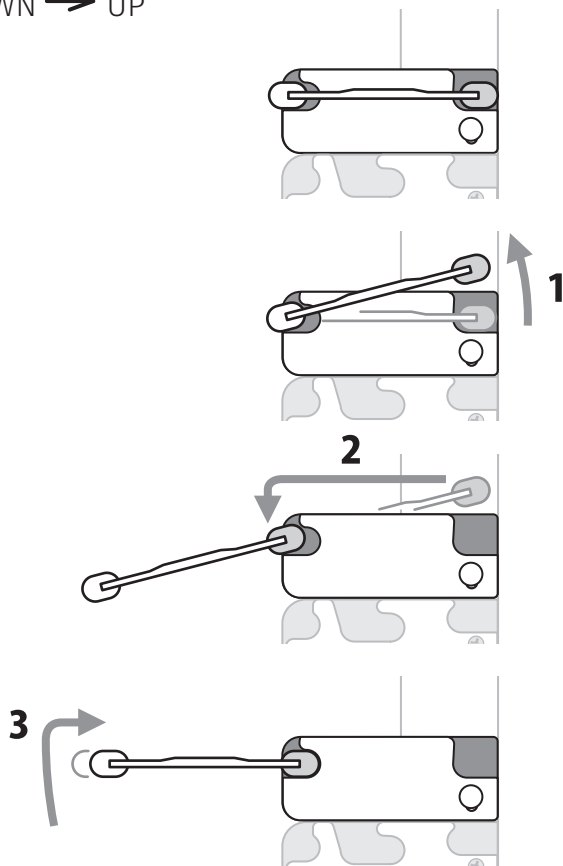

### UP → DOWN

